

1

8X C M6X25

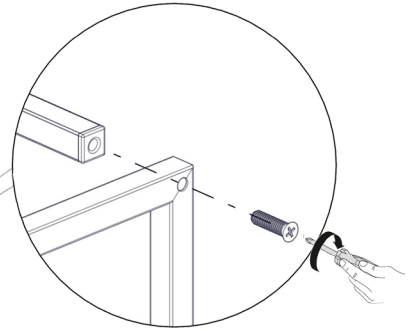

\*Şarjlı/Akülü vidalamada tork ayarı Max 4Nm olmalıdır.

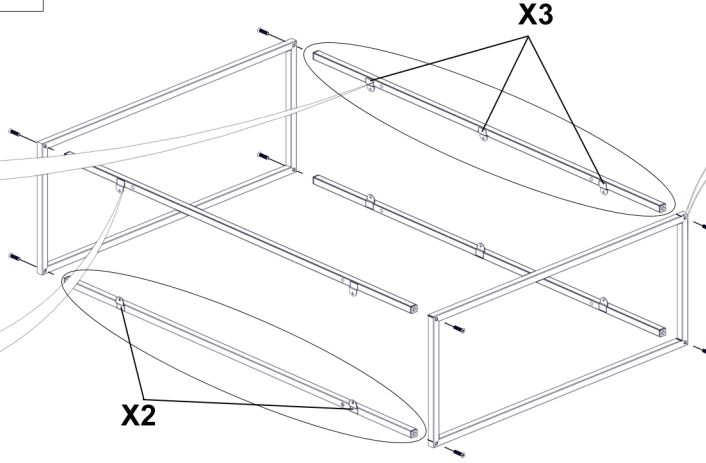
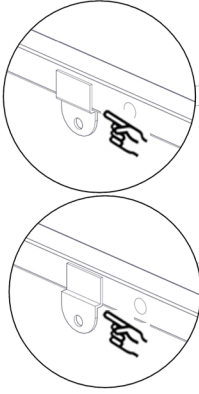
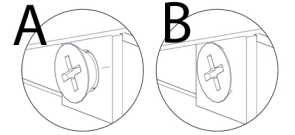

\*Önce bütün vidaları "Şekil A'daki konuma getiriniz, ardından "Şekil B" konumuna getiriniz.

2

8X B M6X12

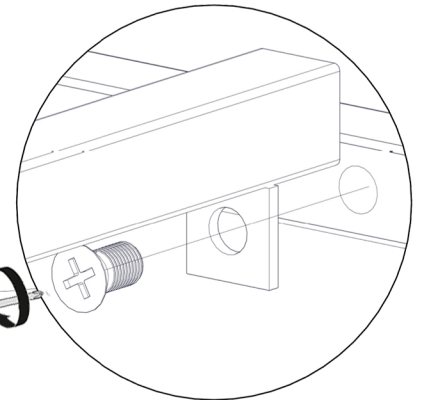
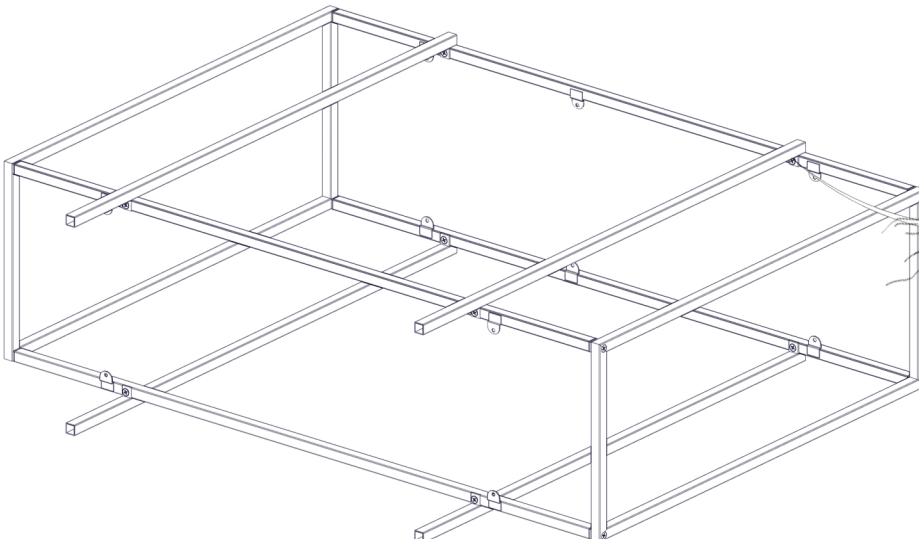

3

4X A 3,5X16 SUNTA VIDASI

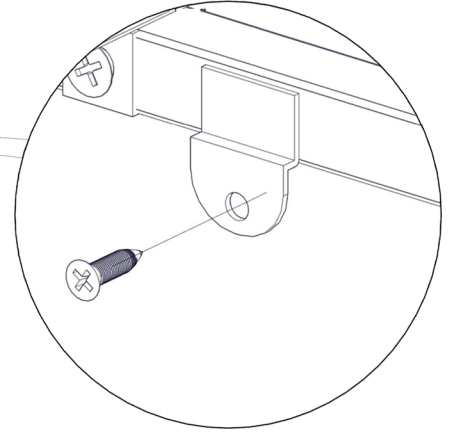
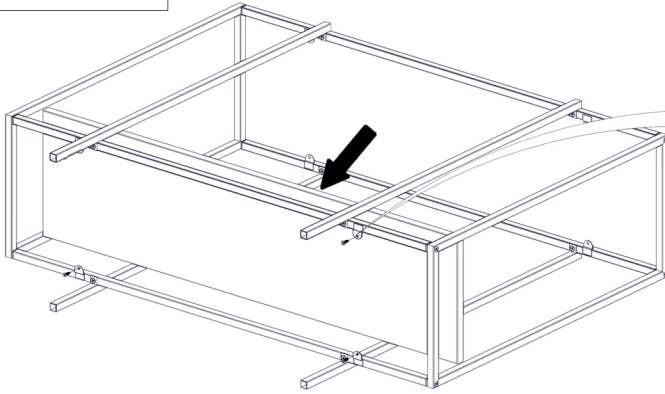

4

4X D VANTUZ

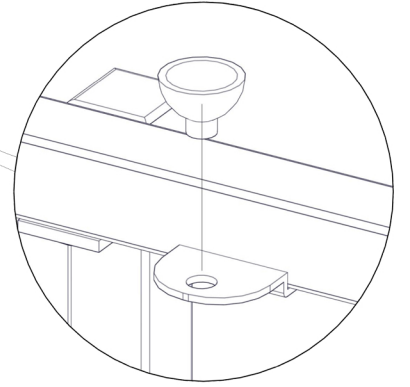
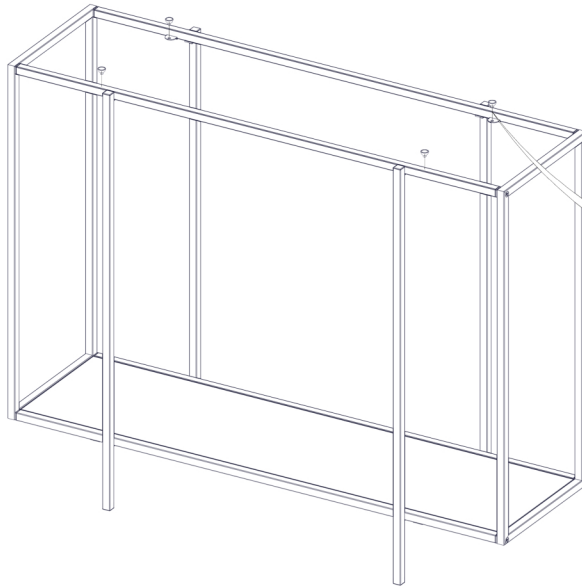
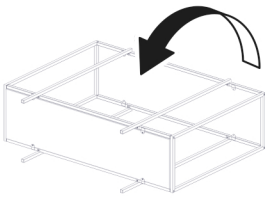

5

