

# 2 KAPAKLI 1 ÇEKMECELİ TV SEHPASI

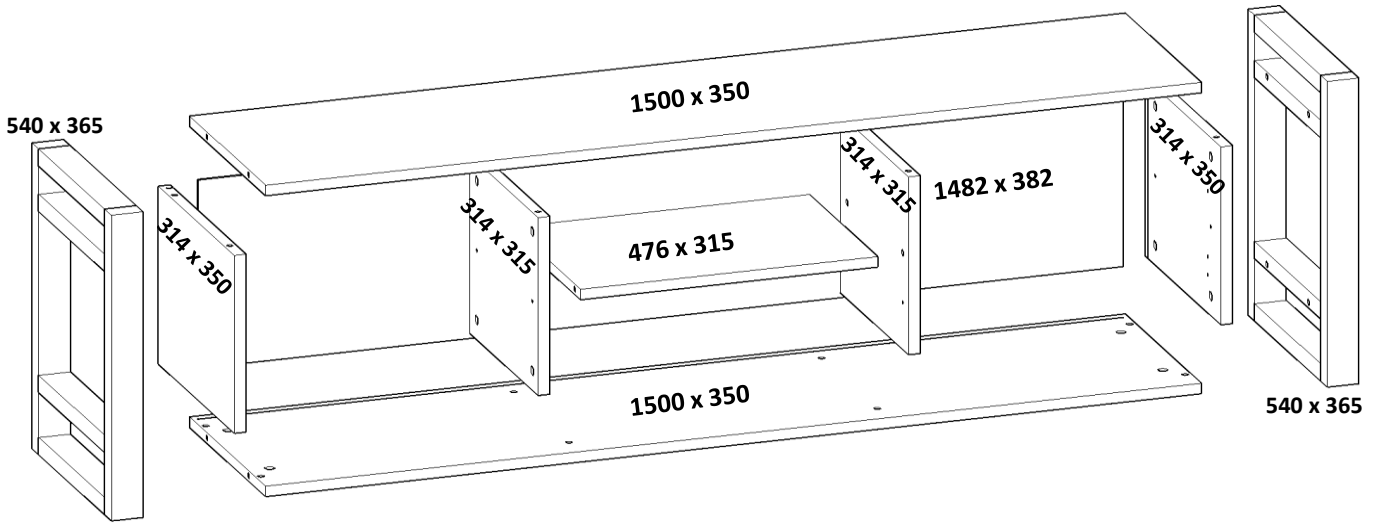

PARÇA SIRASI	PARÇA ADI	PARÇA ADEDİ
1	SAĞ YAN ( 314 mm X 350 mm )	1
2	SOL YAN ( 314 mm X 350 mm )	1
3	ÜST TABLA ( 1500 mm X 350 mm )	1
4	ALT TABLA ( 1500 mm X 350 mm )	1
5	ORTA DİKME ( 314 mm X 315 mm )	2
6	KAPAK ( 484 mm X 308 mm )	2
7	ÇEKMECE ÖN ( 484 mm X 176 mm )	1
8	ORTA SABİT RAF ( 476 mm X 315 mm )	1
9	SAĞ - SOL SEYYAR RAF ( 476 mm X 315 mm )	2
10	ÇEKMECE YAN ( 300 mm X 100 mm )	2
11	ÇEKMECE ARKA KAYIT ( 414 mm X 100 mm )	1
12	ÇEKMECE ALTI ( 3 mm ) ( 430 mm X 298 mm )	1
13	ARKALIK ( 3 mm ) ( 1482 mm X 332 mm )	1
14	PROFİL AYAK ( 540 mm X 365 mm )	2

AKSESUAR : A  
MINİFIX GÖVDE

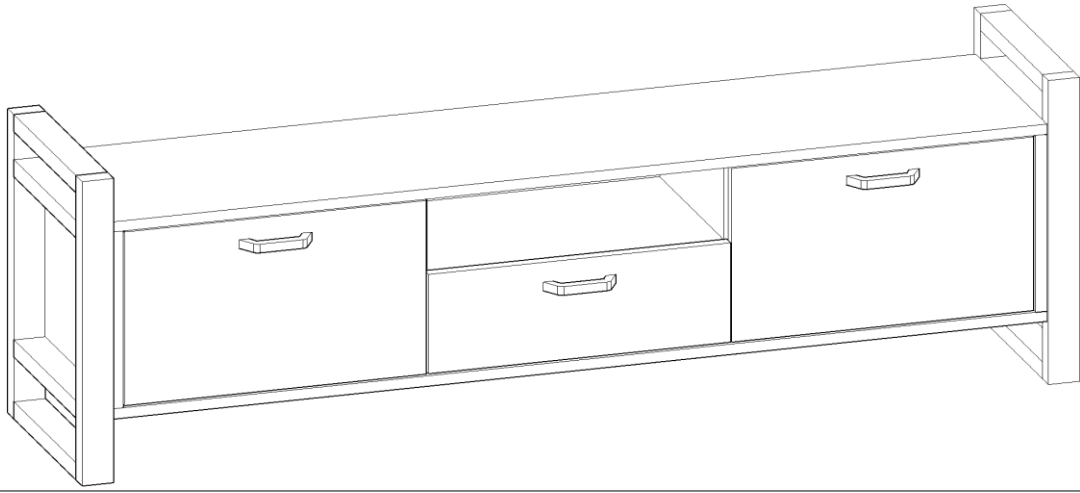

ADET ÖLÇÜ  
32 Ø:15

AKSESUAR : B  
MINİFIX MİL



ADET ÖLÇÜ  
32 Ø:6

AKSESUAR : C  
MINİFIX DÜBEL



ADET ÖLÇÜ  
32 Ø:8

AKSESUAR : D  
KAVELA



ADET ÖLÇÜ  
4 Ø:8

AKSESUAR : E  
YILDIZ VIDA



ADET ÖLÇÜ  
32 3,5x18

AKSESUAR : F  
YILDIZ VIDA



ADET ÖLÇÜ  
6 4x30

AKSESUAR : G  
TELESKOPİK RAY



TAKIM ÖLÇÜ  
1 30 CM

AKSESUAR : H  
KULP



ADET ÖLÇÜ  
3 128 MM

AKSESUAR : J  
TAM DEVE MENTEŞE

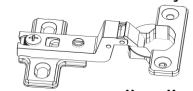

ADET ÖLÇÜ  
4

AKSESUAR : K  
MINİFIX TAPA



ADET RENK  
32 BEYAZ

AKSESUAR : L  
RAF PİMİ

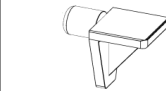

ADET RENK  
8 Ø:5

AKSESUAR : M  
ARKALIK SIKIŞTIRICI



ADET ÖLÇÜ  
8

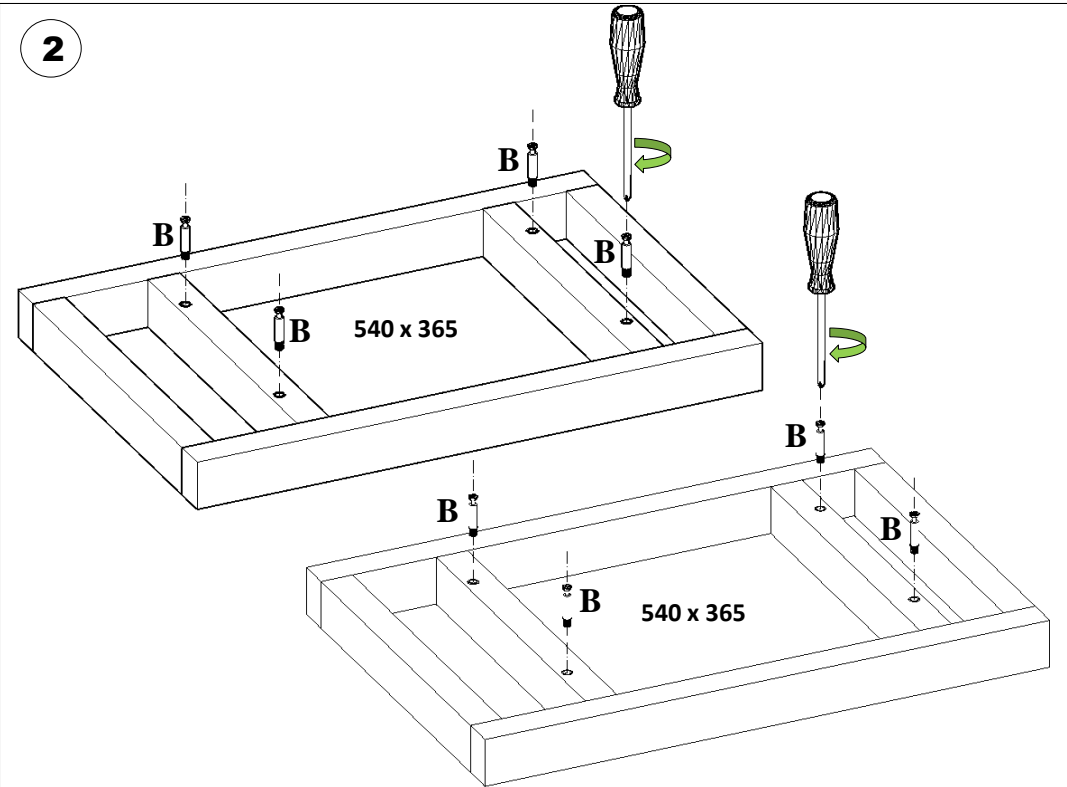
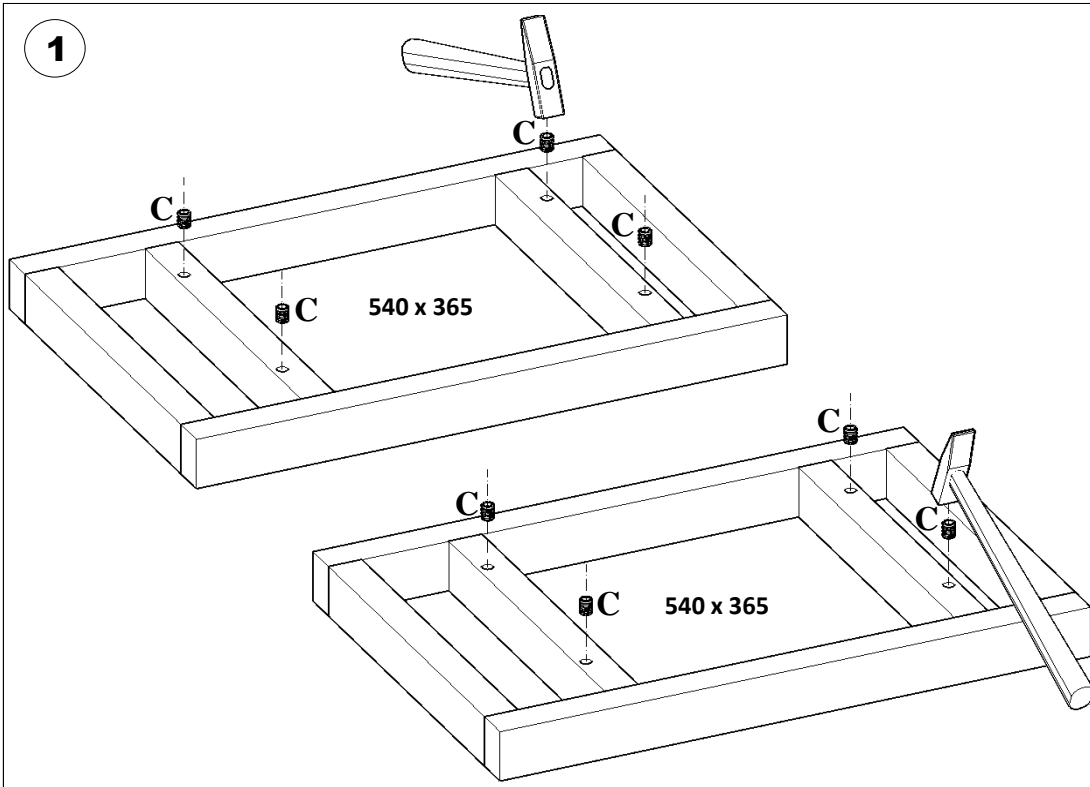

MİNİFIX GÖVDESİ MONTAJLANAN HER PARÇA İÇİN; GÖVDENİN ÜZERİNDEKİ AÇIK TARAFIN MİLİNİN YUVASINA DENK GELECEK ŞEKİLDE MONTAJ EDİLMESİNE DİKKAT EDİLİM.

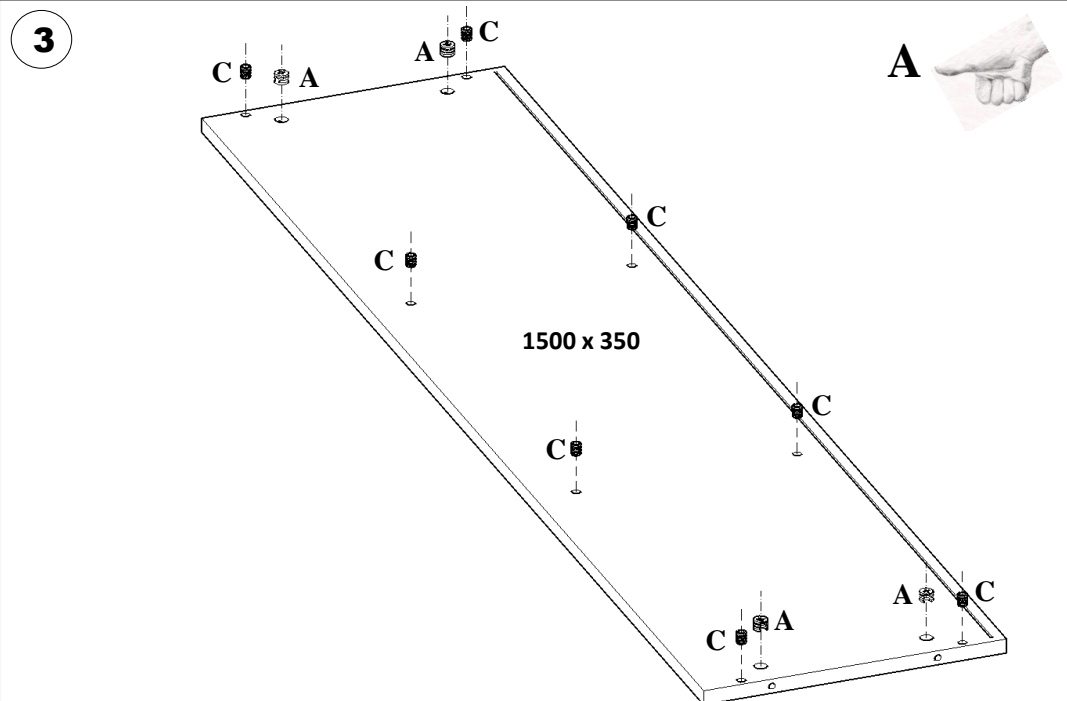
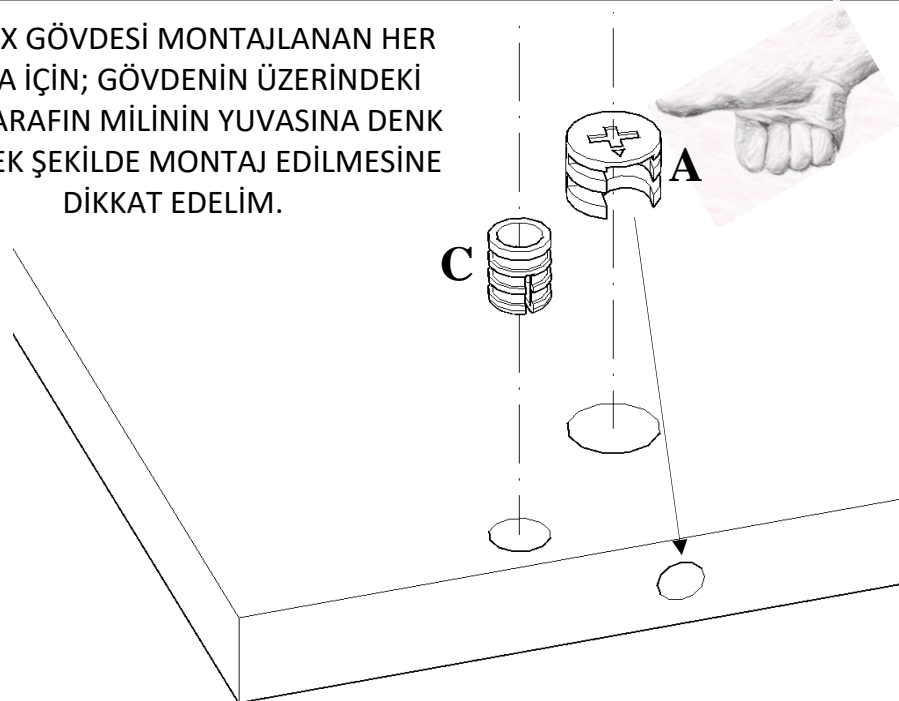

4

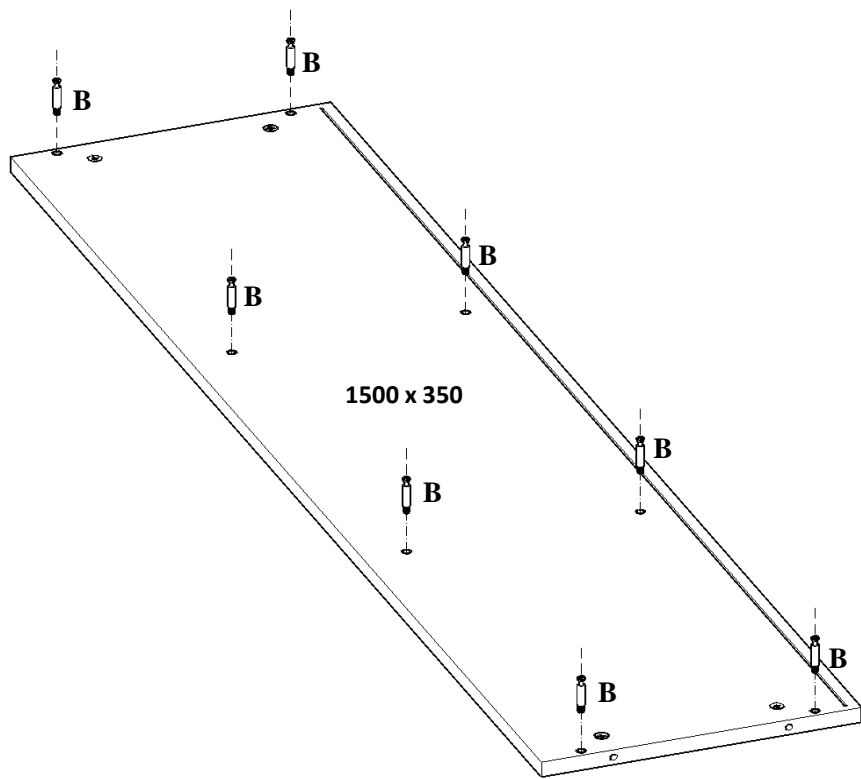

5

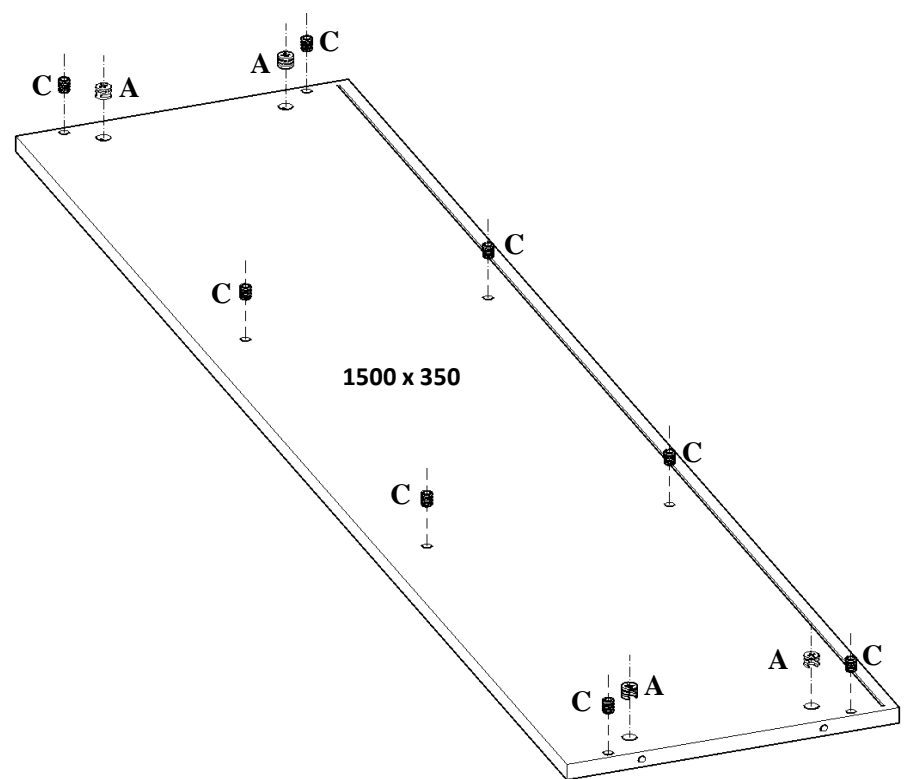

6

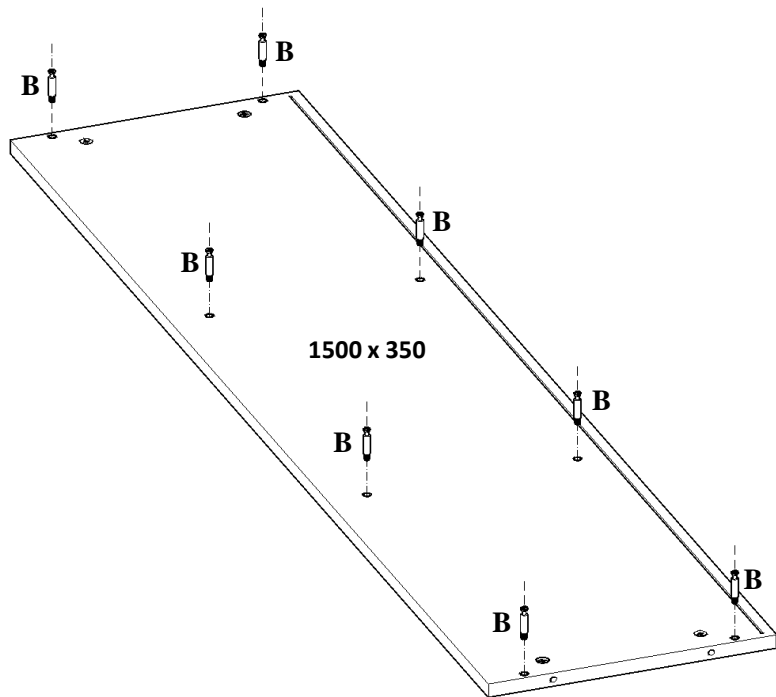

7

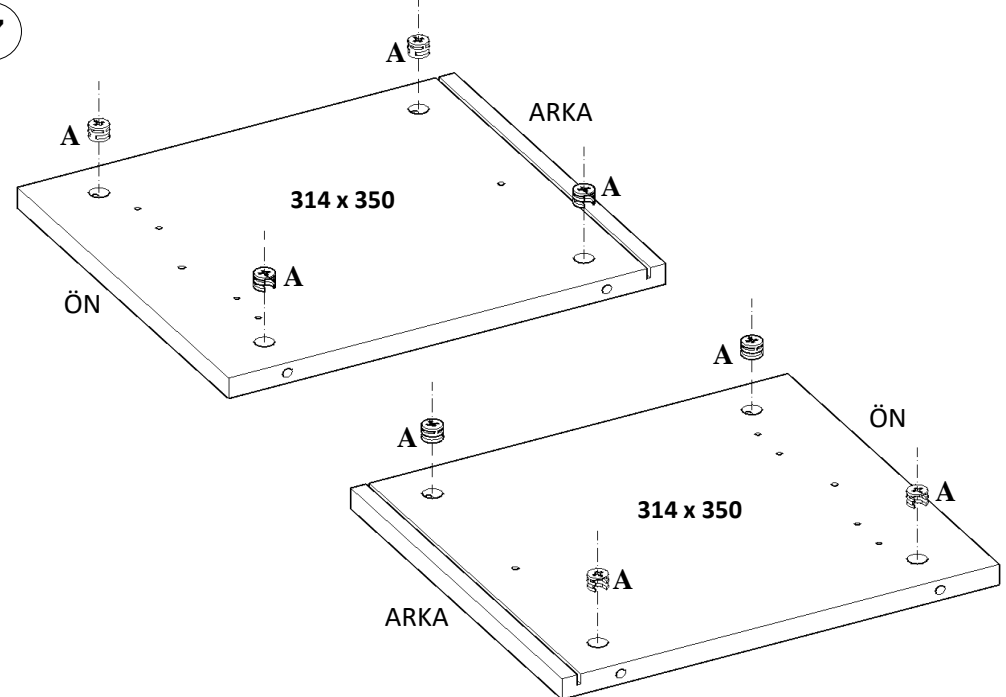

8

G1



G2

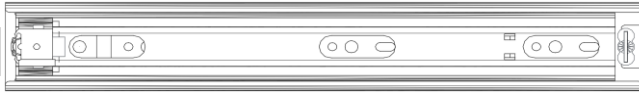

RAYI SONUNA KADAR  
AÇTIĞINIZDA  
BİRBİRİNDEN AYIRMAK  
İÇİN; MANDALI AŞAĞIYA  
İTMENİZ YETERLİDİR.

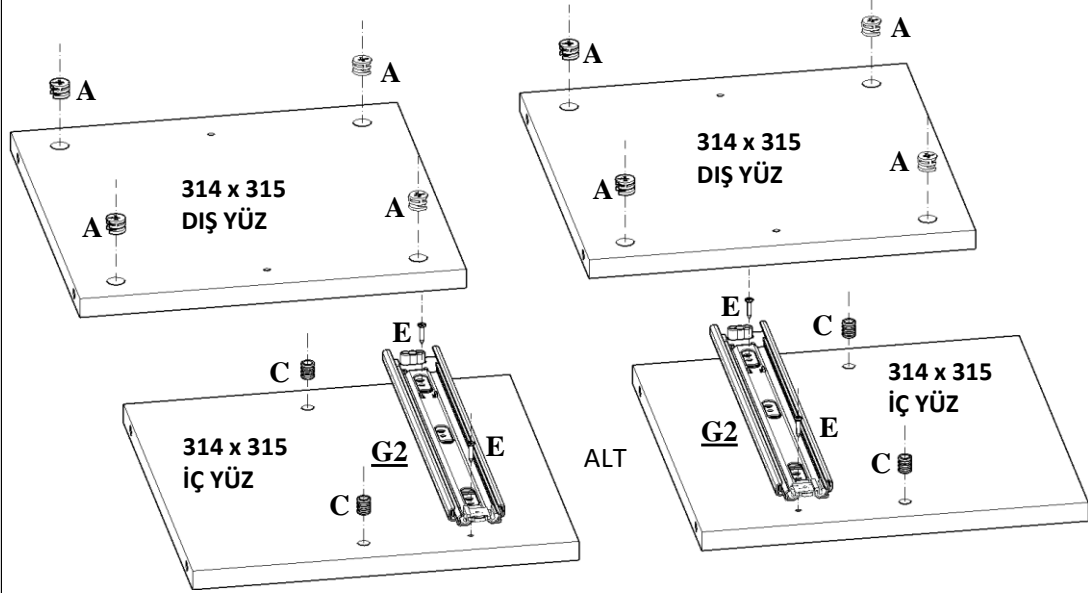

9

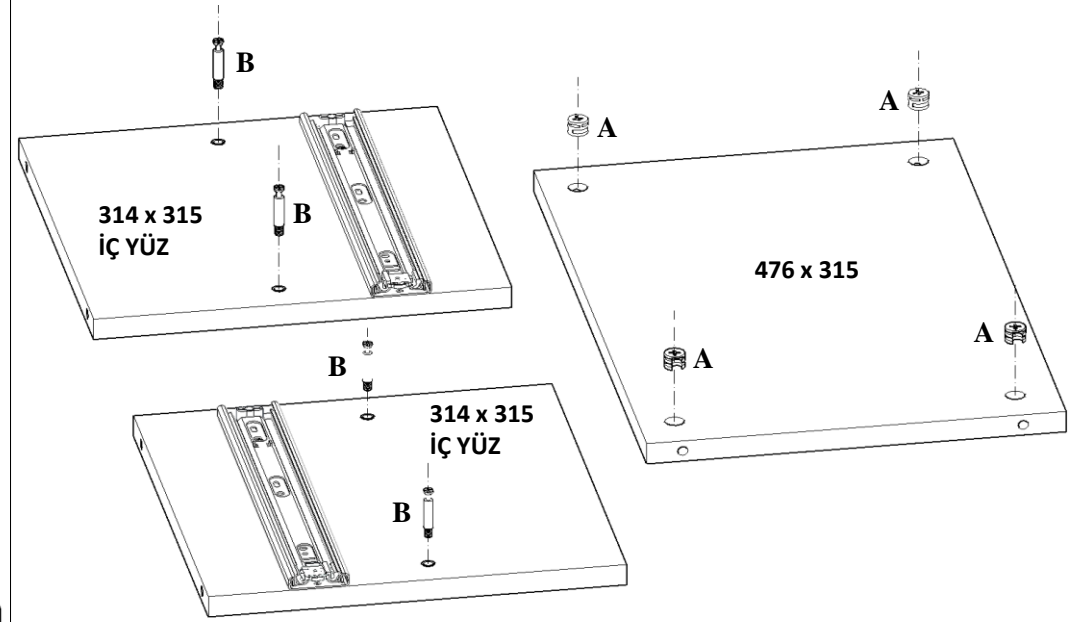

10

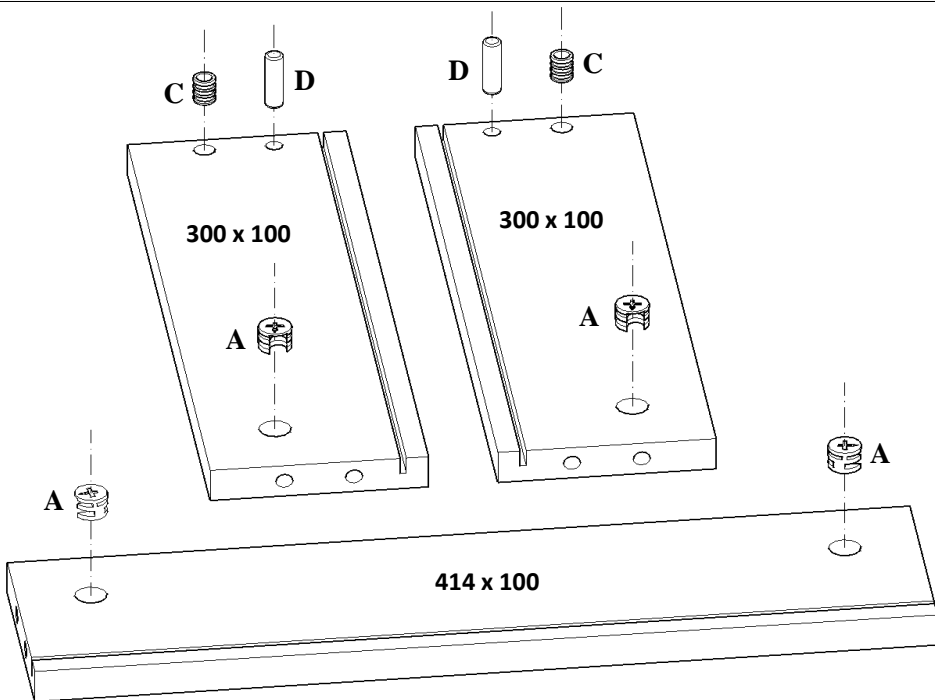

11

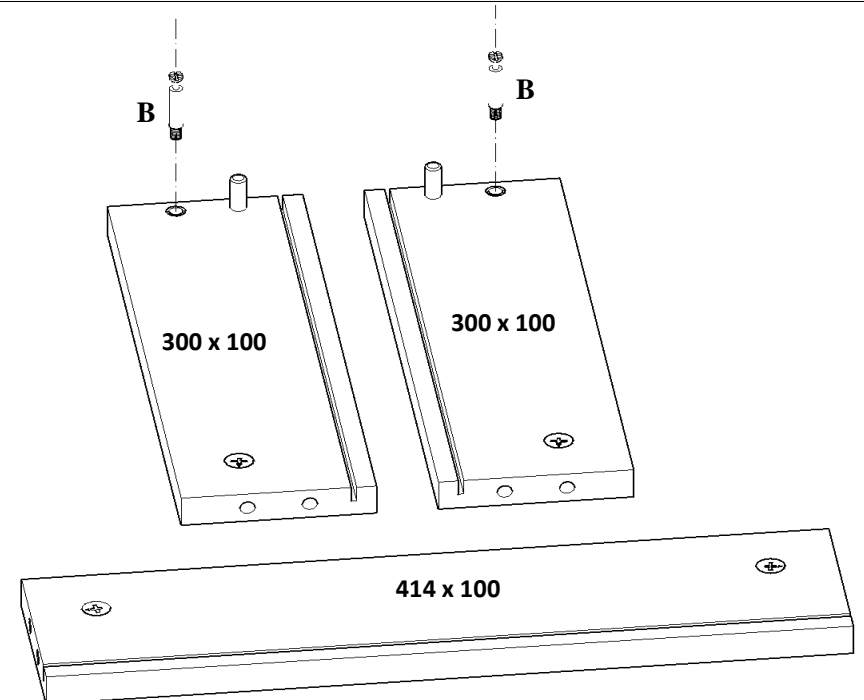

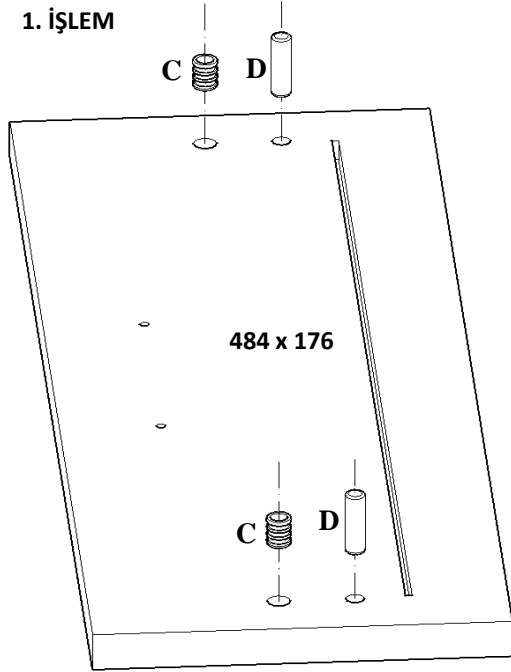
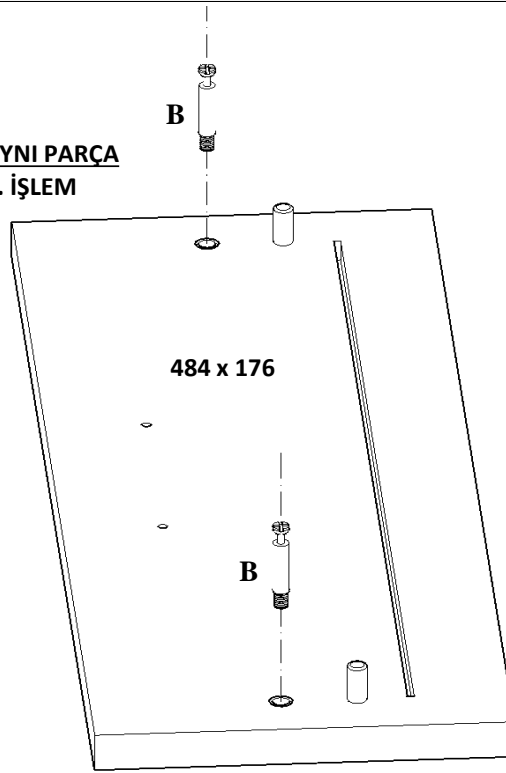
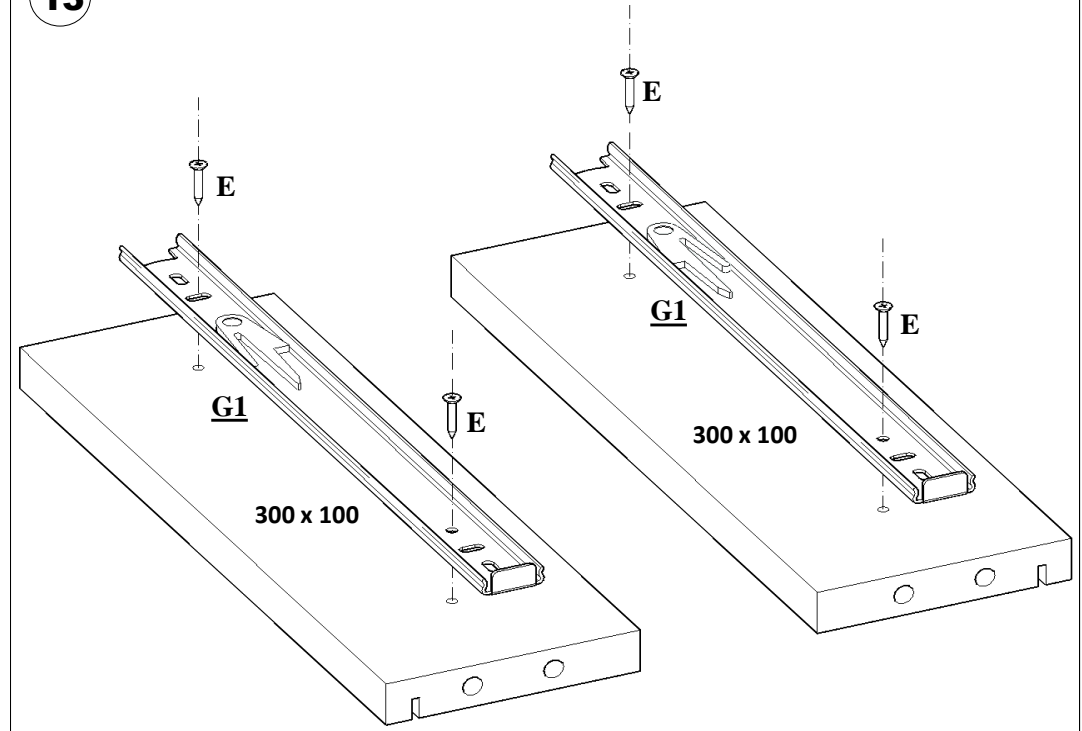
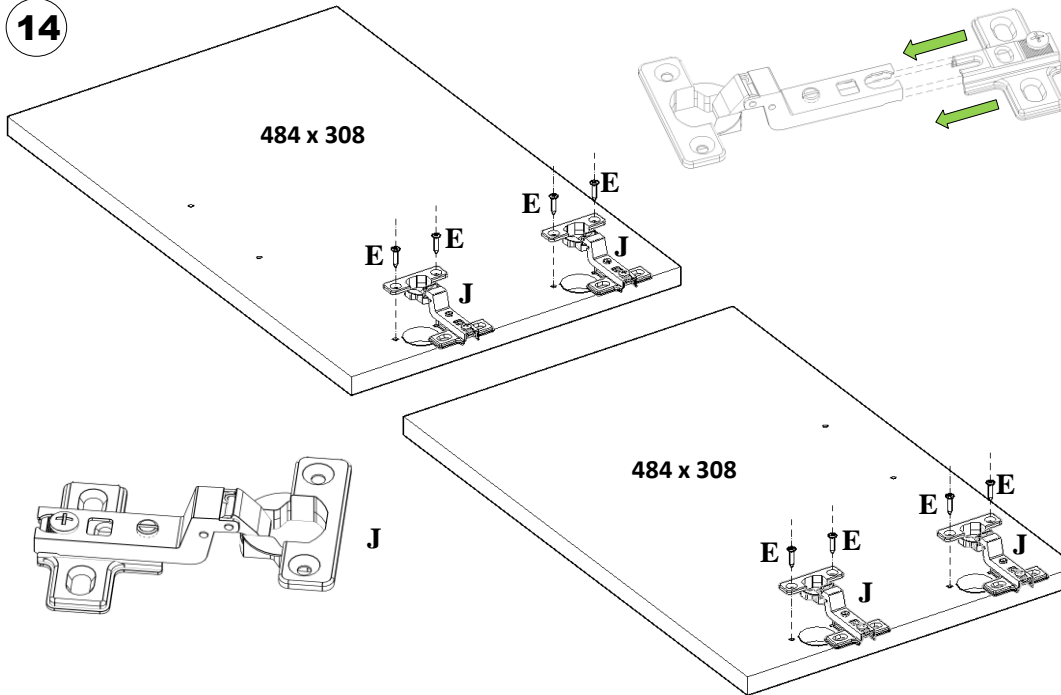
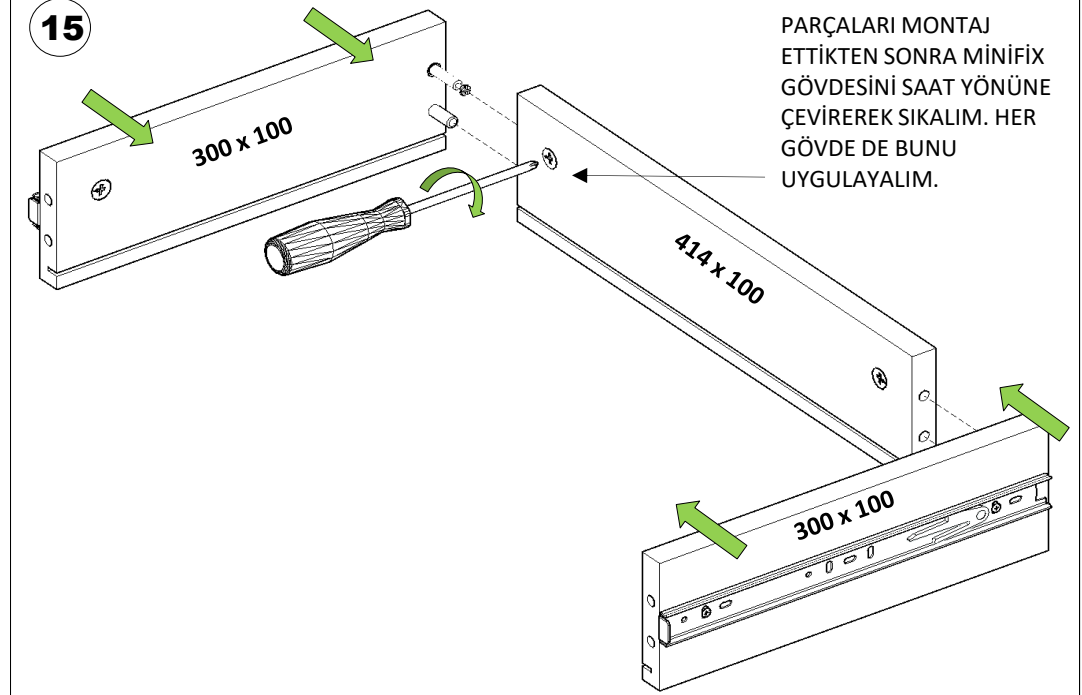
**12****1. İŞLEM****AYNI PARÇA**  
**2. İŞLEM****13****14****15**

PARÇALARI MONTAJ  
ETTİKTEN SONRA MİNİFİX  
GÖVDESİNİ SAAT YÖNÜNE  
ÇEVİREREK SIKALIM. HER  
GÖVDE DE BUNU  
UYGULAYALIM.

16

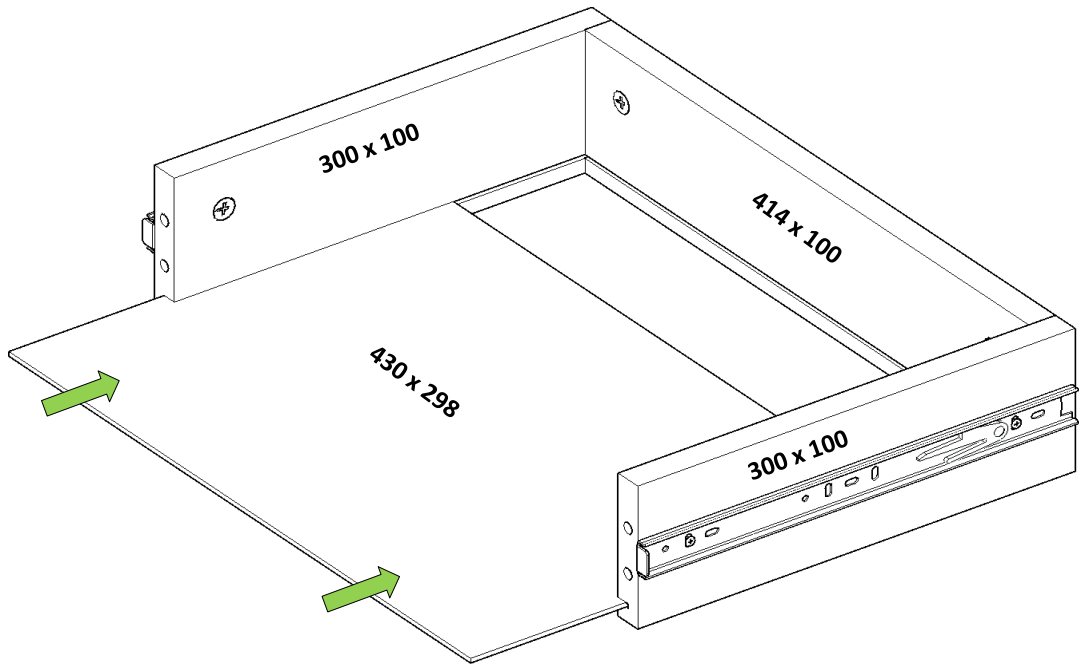

17

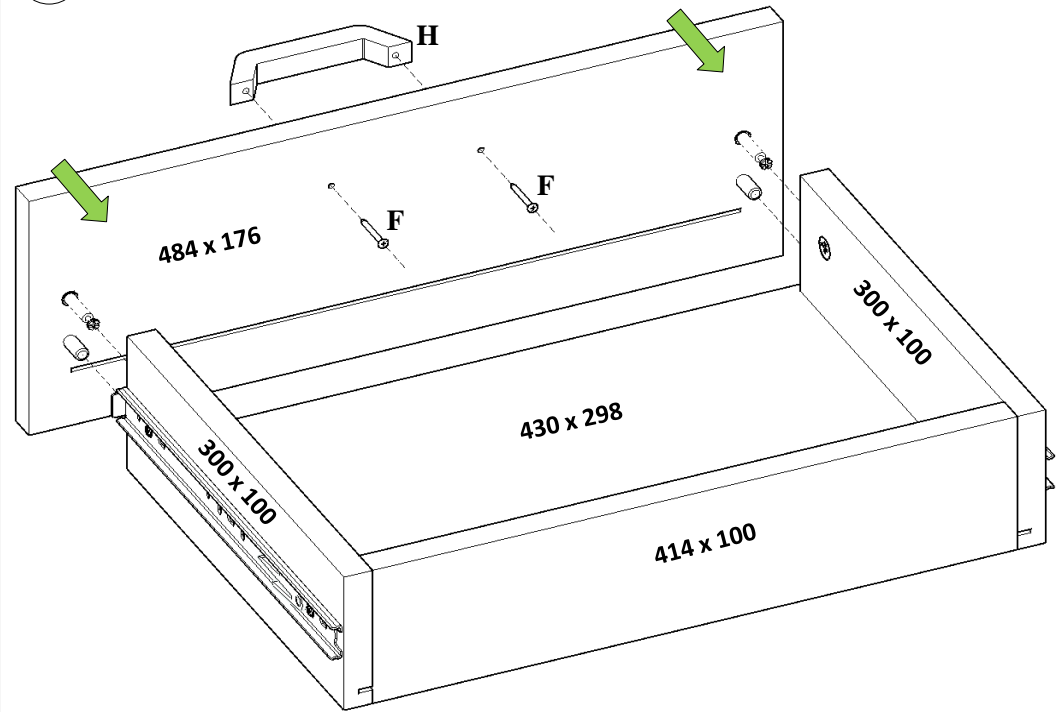

18

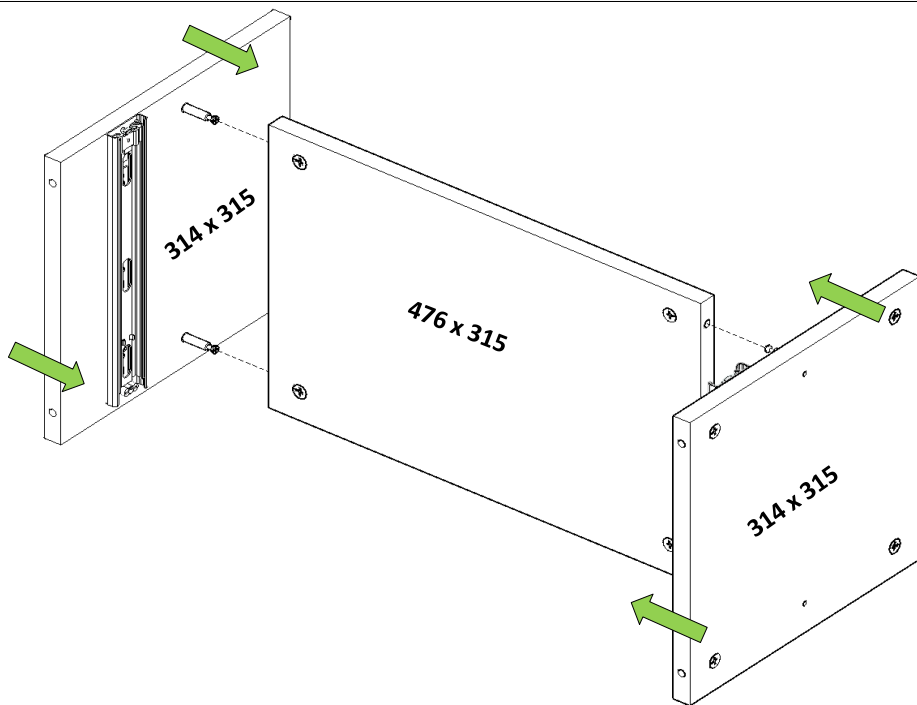

19

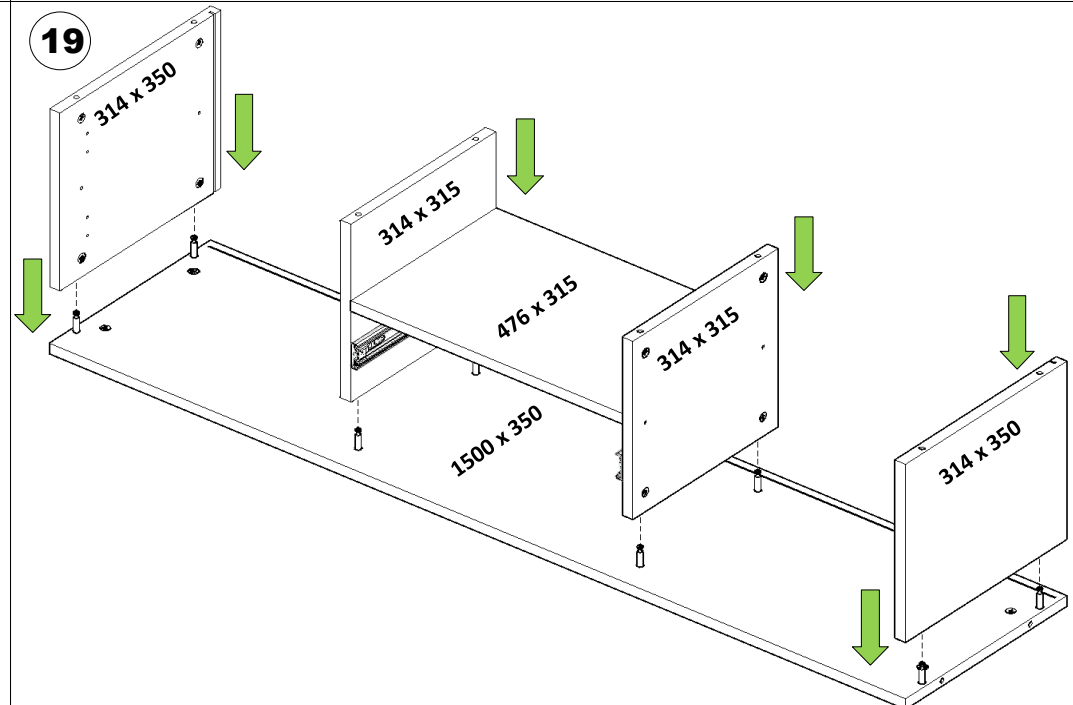

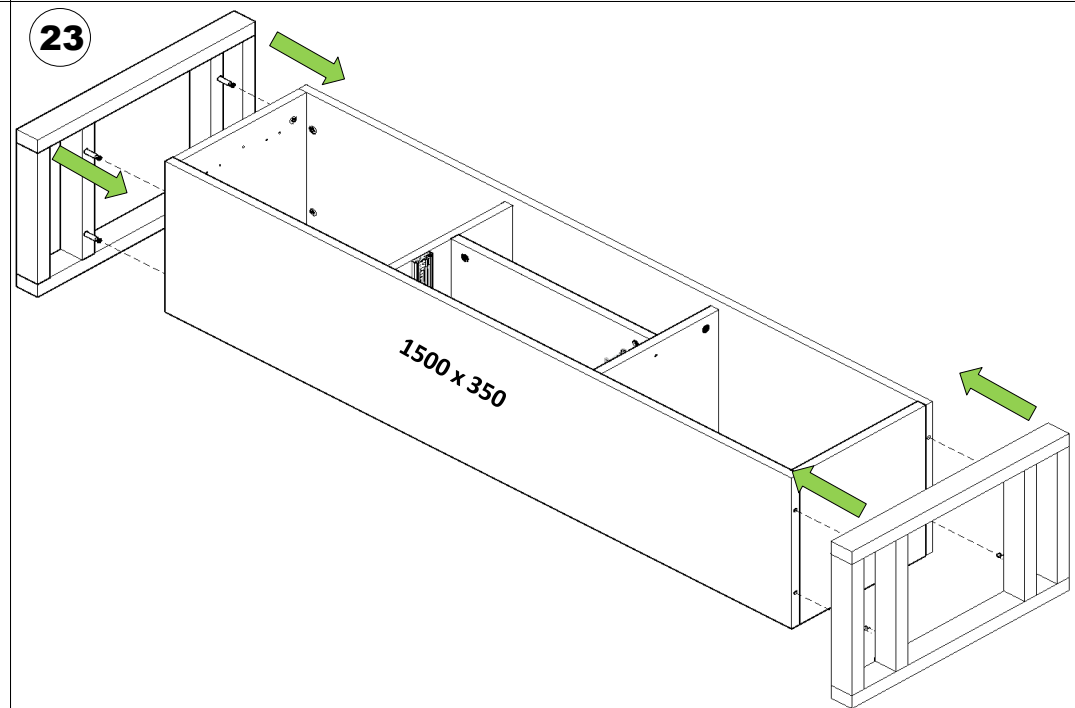
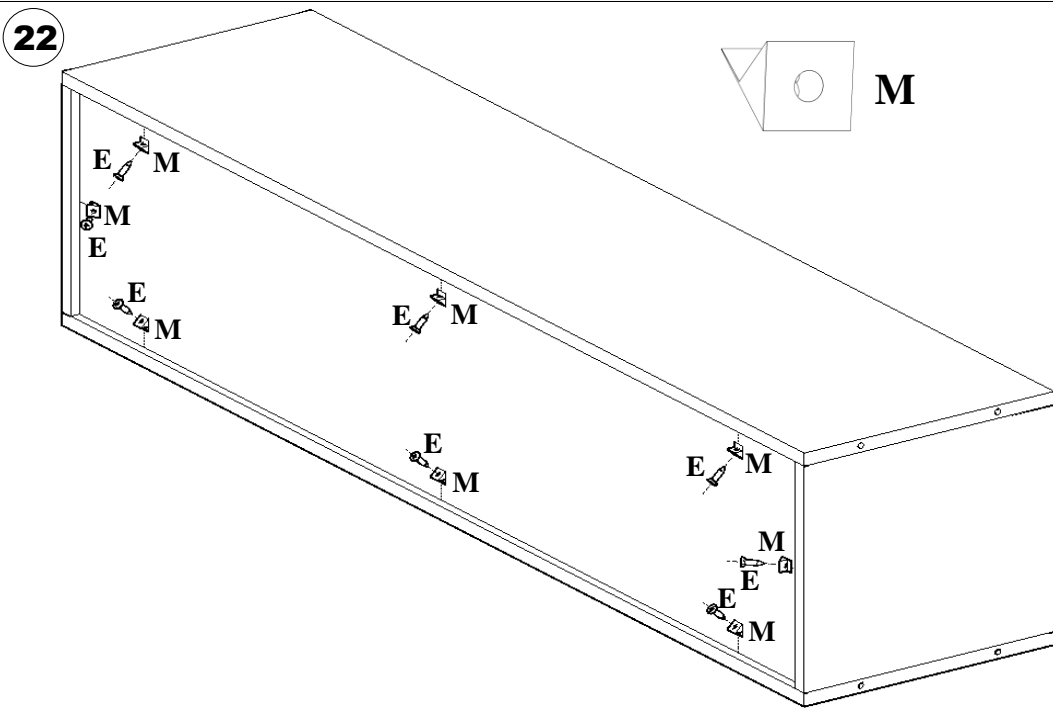
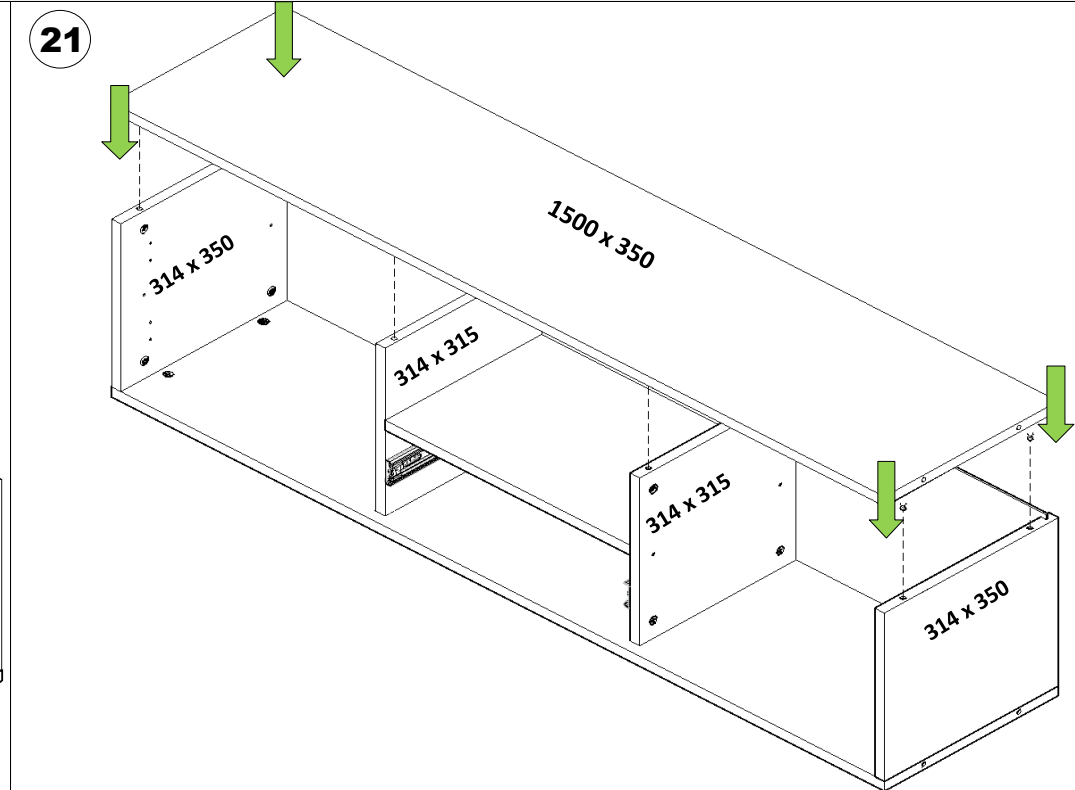
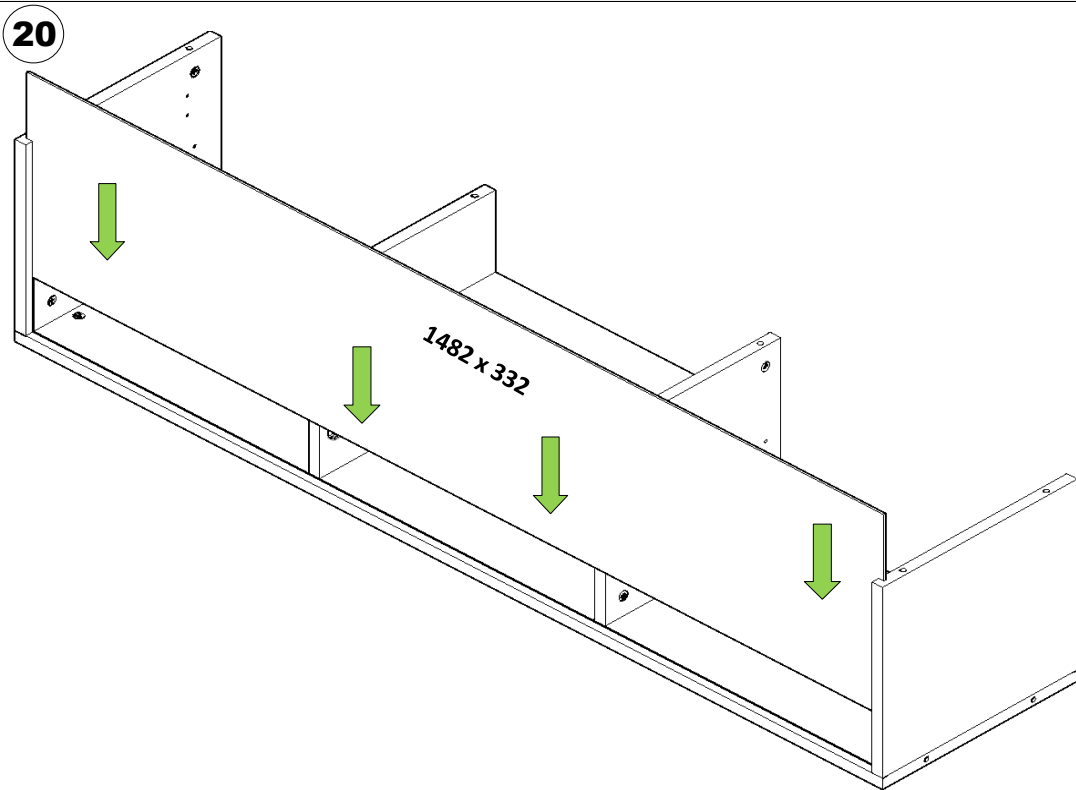

24

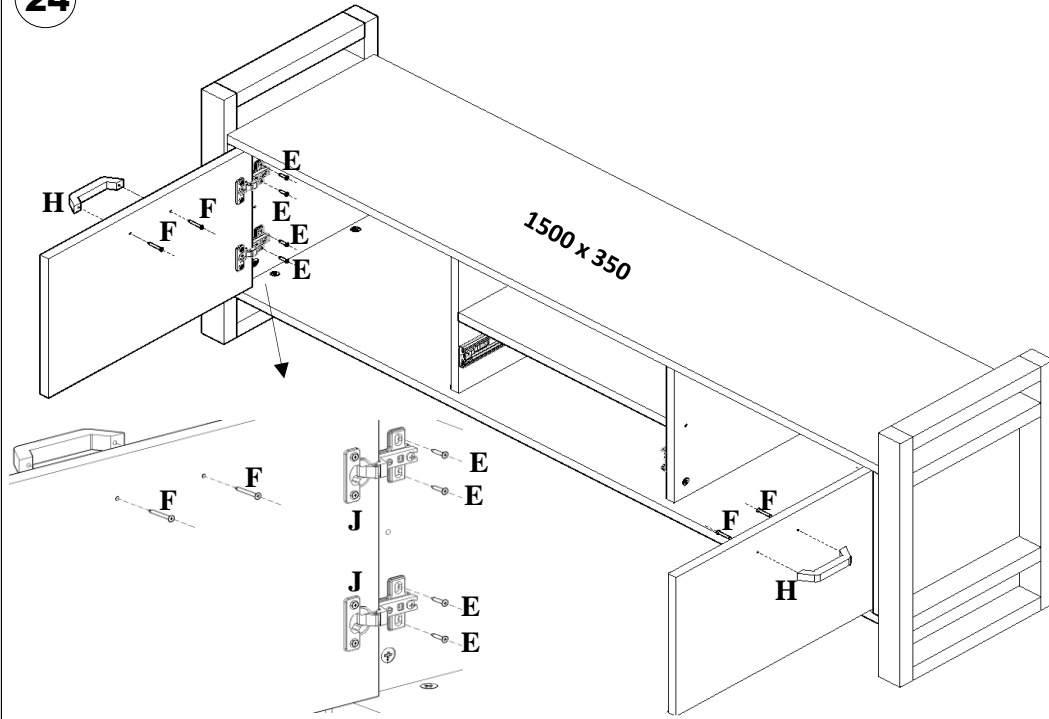

25

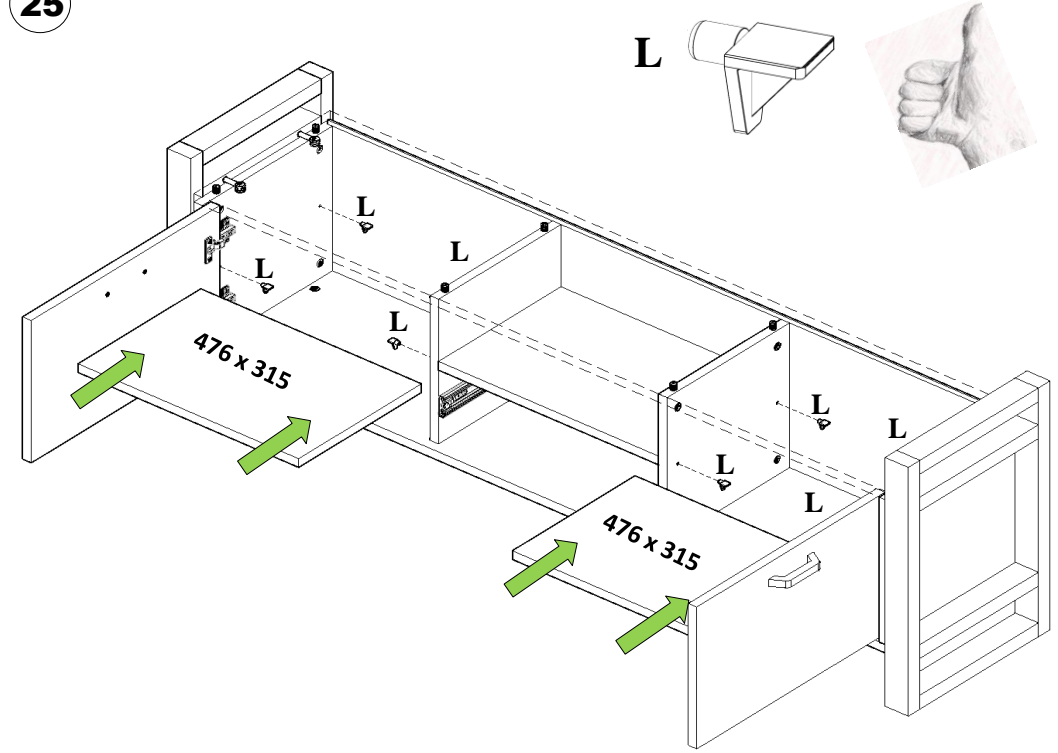

26

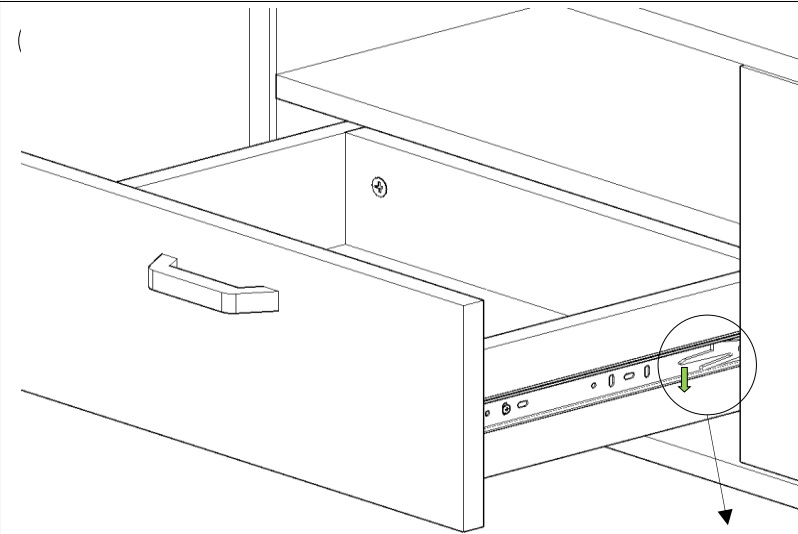
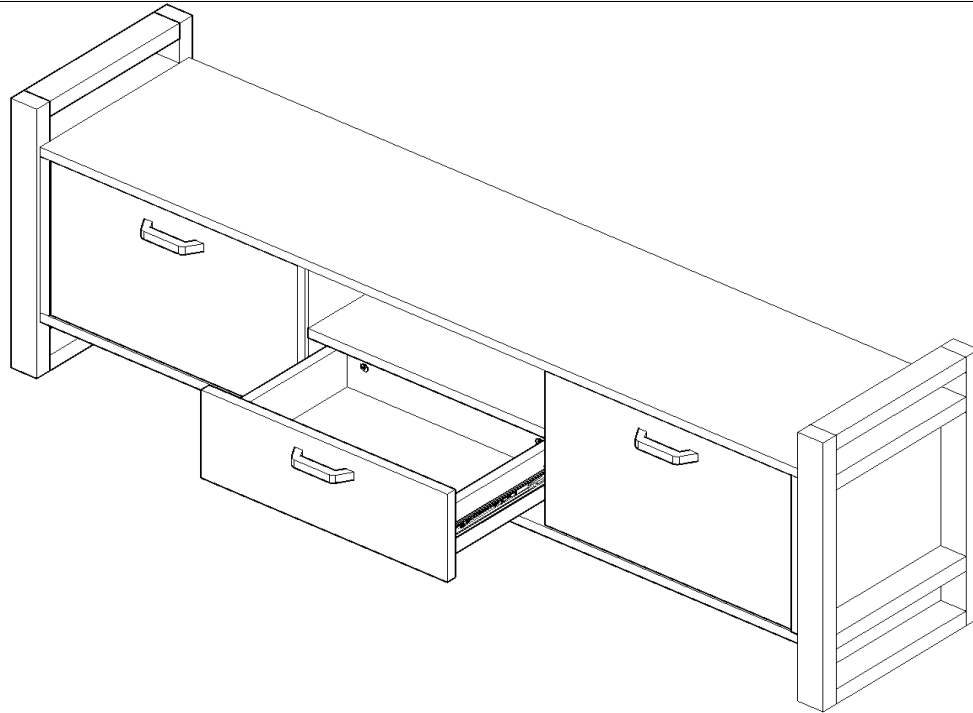

DETAY RESMİNDE GÖRÜLDÜĞÜ ÜZERE; ÇEKMEYİ AÇTIKTAN SONRA GÖZÜKEN, ÇEKMECENİN SAĞ VE SOL TARAFINDA BULUNAN MANDALLARIN **SOLDAKİNİ, YUKARIYA ÇEKEREK, SAĞDAKİNİ AŞAĞIYA İTEREK** ÇEKMECE KASASINI GÖVDEDEN AYIRABİLİRSİNİZ.