

① YAN METAL DESTEKLER 2X	② ALT METAL DESTEKLER 2X	③ ALT TABLA 1X	④ ORTA TABLA 1X	⑤ ÜST TABLA 1X	⑥ SOL VE SAĞ YAN PARÇALAR 2X	⑦ ORTA RAF DESTEKLERİ 2X	⑧ ORTA SOL İÇ PARÇA 1X	⑨ ORTA SAĞ İÇ PARÇA 1X	⑩ KAPAK 3X	⑪ MİNİFİX TAPASI 24X	⑫ 3.5x18mm VİDA 36X	⑬ MENTEŞE 6X	⑭ BAĞLANTI RAYI 3X	⑮ ARKALIK 1X	⑯ KAVELA 24X	⑰ MİNİFİX GÖVDE 24X	⑱ MİNİFİX MİLİ 24X	⑲ MİNİFİX MİLİ 24X	⑳ METAL MONTAJ VİDASI 16X	㉑ ÇEKMECE KULP 3X	㉒ KULP VİDASI 6X
--------------------------------	--------------------------------	----------------------	-----------------------	----------------------	---------------------------------------	--------------------------------	---------------------------------	---------------------------------	------------------	----------------------------	---------------------------	--------------------	-----------------------------	--------------------	--------------------	------------------------------	--------------------------	--------------------------	---------------------------------------	----------------------------	------------------------

A

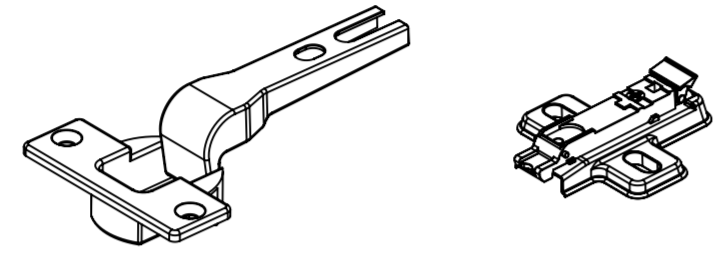

MENTEŞE-K

MENTEŞE-T

NOT: MENTEŞE MONTAJINDA, MENTEŞE-T İSİMLİ PARÇA, TABLAYA MONTE EDİLİR, MENTEŞE-K İSİMLİ PARÇA İSE KAPAĞA MONTE EDİLİR. DİK BİR ŞEKİLDE TAKILDIĞINDAN EMİN OLUNUP UYGUN VİDALAR İLE MONTAJI GERÇEKLEŞTİRİLİR.

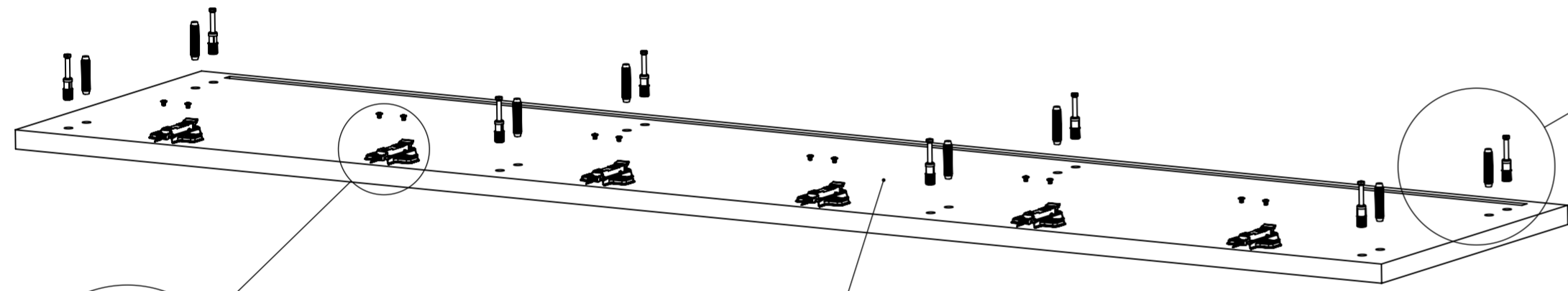

⑫ 3.5x18mm VİDA

③ ALT TABLA

⑬ MENTEŞE

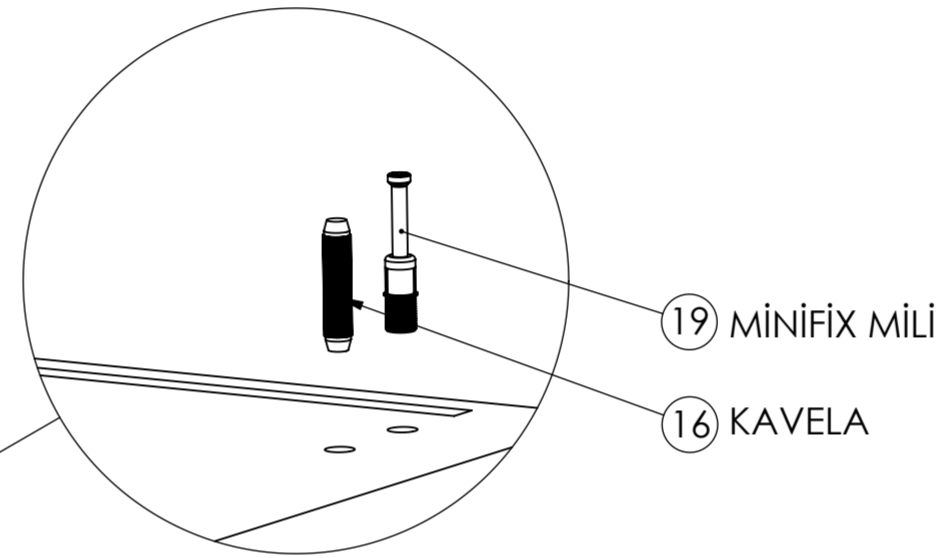

⑲ MİNİFİX MİLİ

⑯ KAVELA

NOT: MİNİFİX MİLLERİNİ ELİNİZLE BASTIRARAK VE YA TORNAVİDA YARDIMI İLE MONTE EDEBİLİRSİNİZ.

B

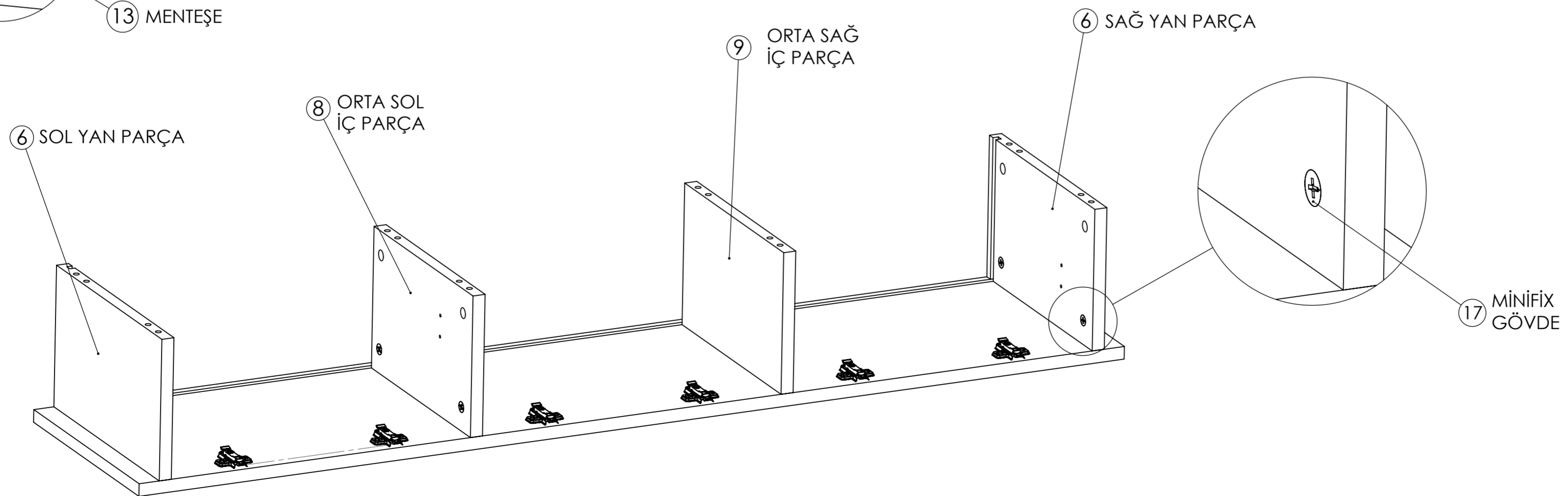

⑥ SOL YAN PARÇA

⑧ ORTA SOL
İÇ PARÇA

⑨ ORTA SAĞ
İÇ PARÇA

⑥ SAĞ YAN PARÇA

⑰ MİNİFİX
GÖVDE

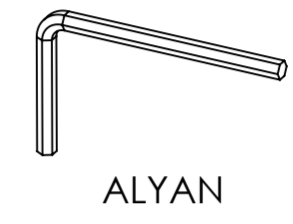

ALYAN

NOT: 20 NUMARALI METAL MONTAJ VİDALARI ALYAN ANAHTARI İLE MONTE EDİLİR. ALYAN ANAHTARI KURULUM POŞETİNDE BULUNMAKTADIR.

ASEMO HOME

EN AZ İKİ KİŞİ
İLE KURUNUZ!



TWO PERSON
ASSEMBLY
REQUIRED !



Certificate

TR
Garanti şartlarının geçerli olması için kurulum şemasındaki sıraya uygun olarak montaj yapılması gerekmektedir. Hatasız ve daha kolay montaj için tüm parçaları önce geniş ve düz zemine diziniz. Şemada gösterilen parça listesi ile ürün kutusundan çıkan parçaları karşılaştırınız. Montajı ürün kolisi üzerinde veya sert ve çizici olmayan bir zeminde, parça kutusundan çıkan «L» şeklindeki alyan anahtarı ile yapınız. Kurulum şemasını ve garanti belgesini, ödeme evraklarınızla saklayınız.

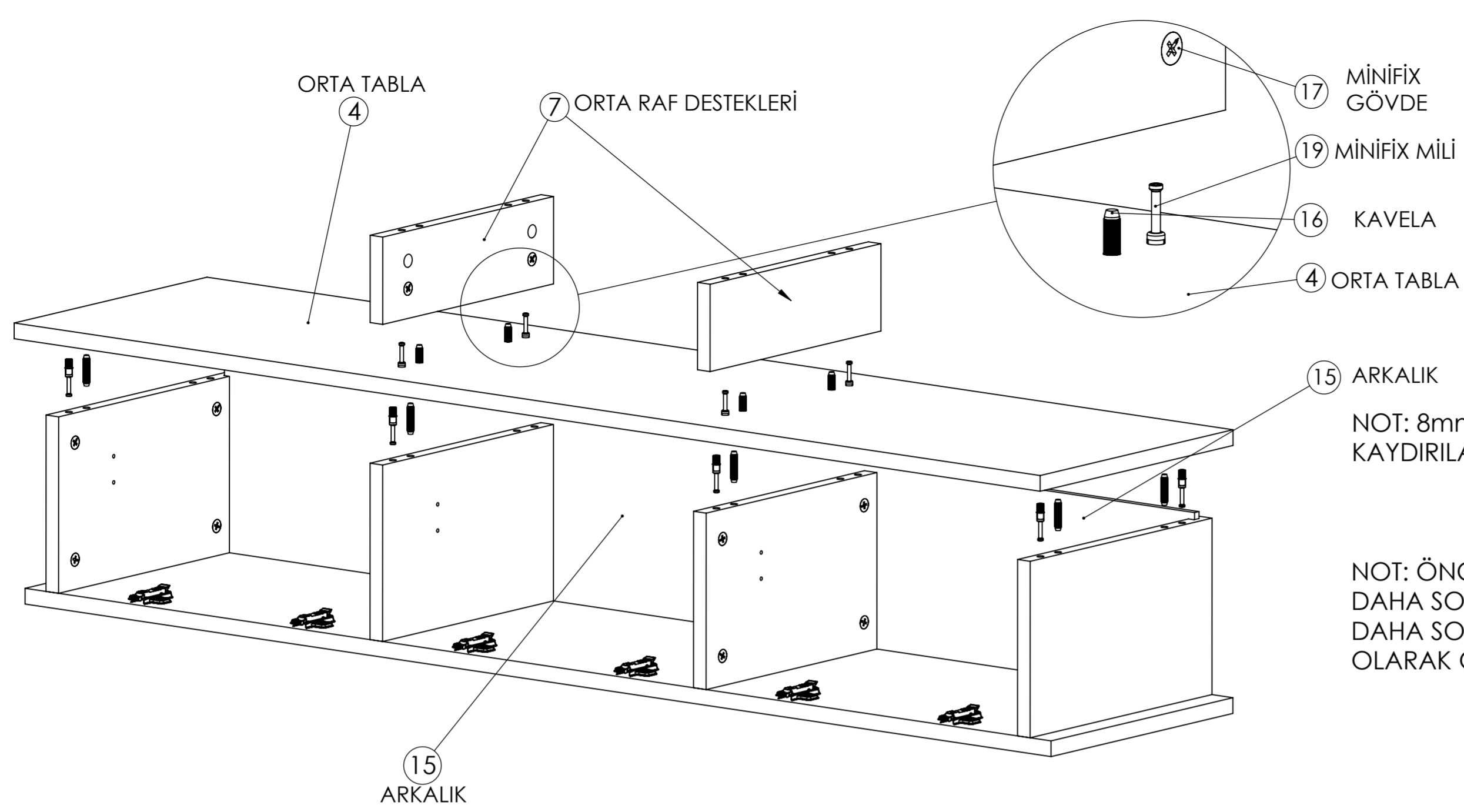
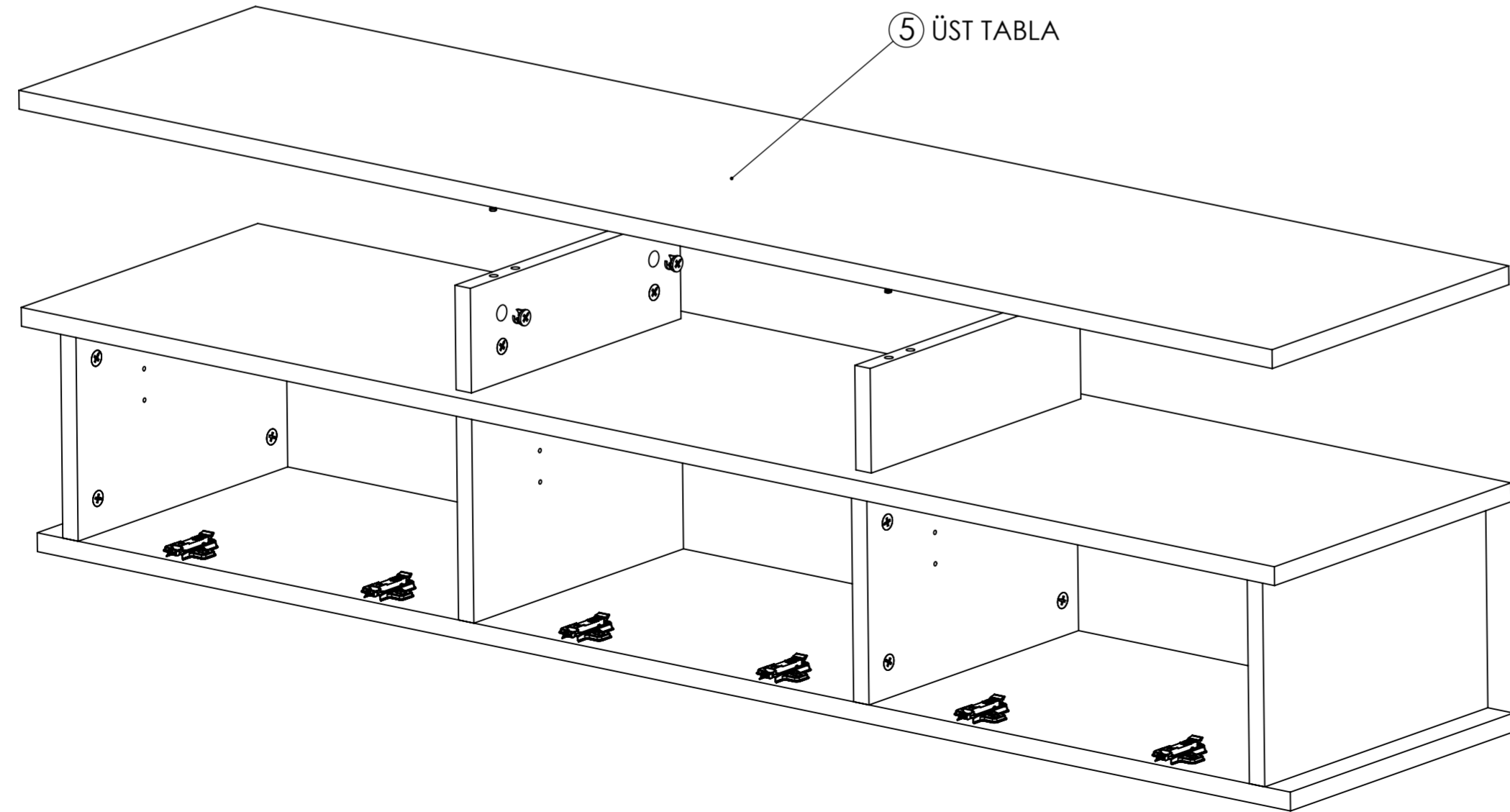
C**D**

NOT: ÖNCE ÜST TABLAYA MİNİFİX MİLİ VE KAVELALAR TAKILARAK GÖVDEYE MONTE EDİLİR, DAHA SONRA 2 NOLU ALT METAL DESTEKLER, VİDALAR YARDIMI İLE MONTE EDİLİR.

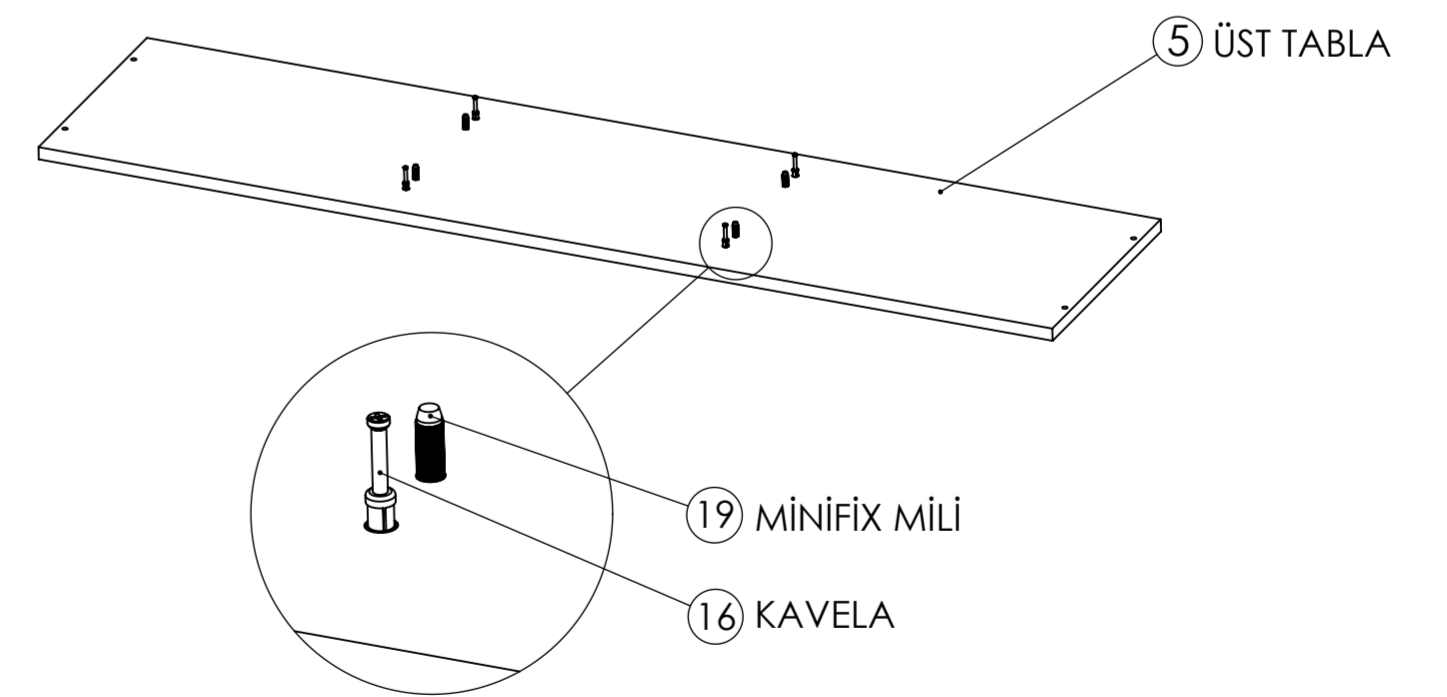

E KULP VE KLAPA MONTAJI

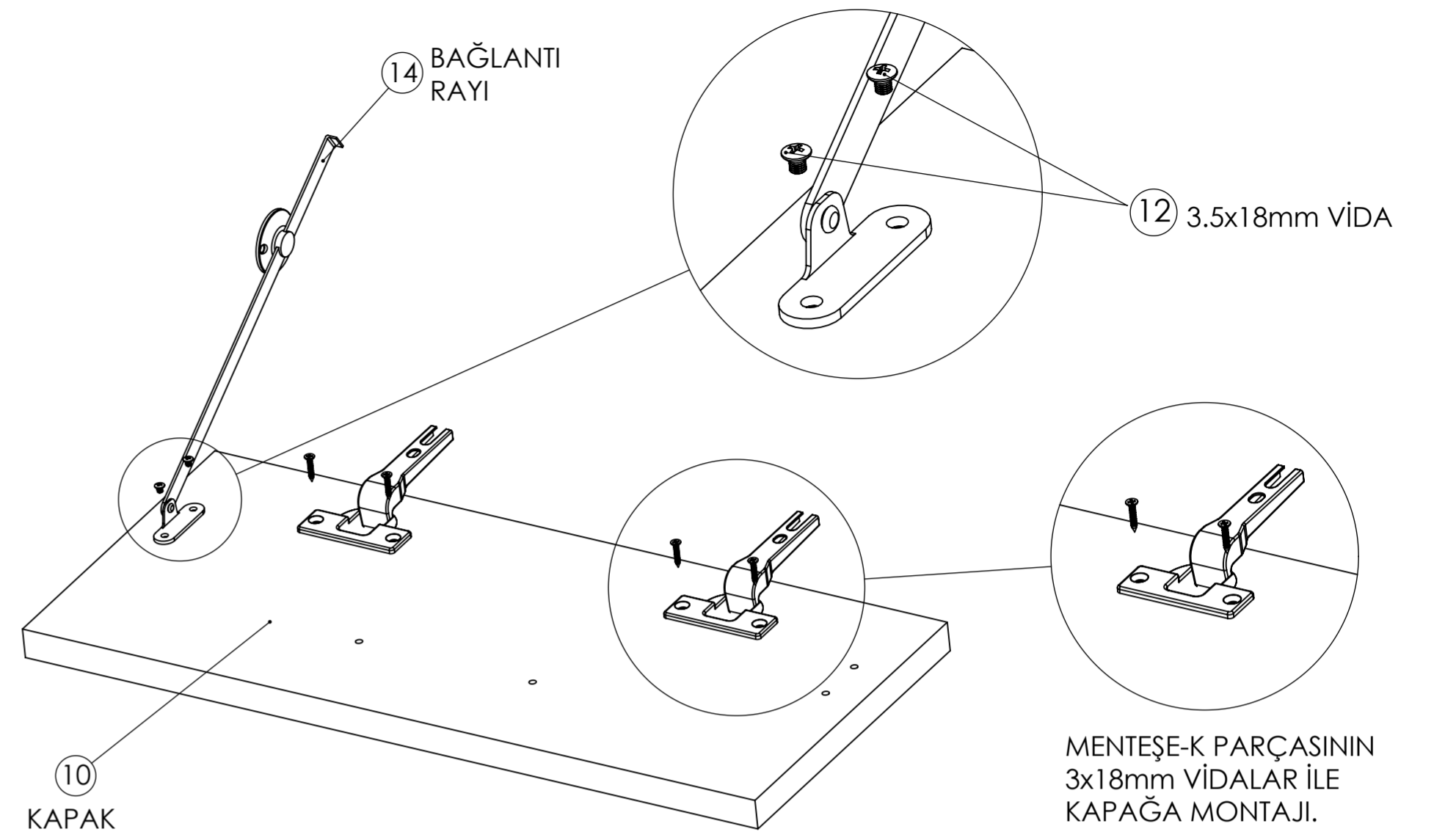
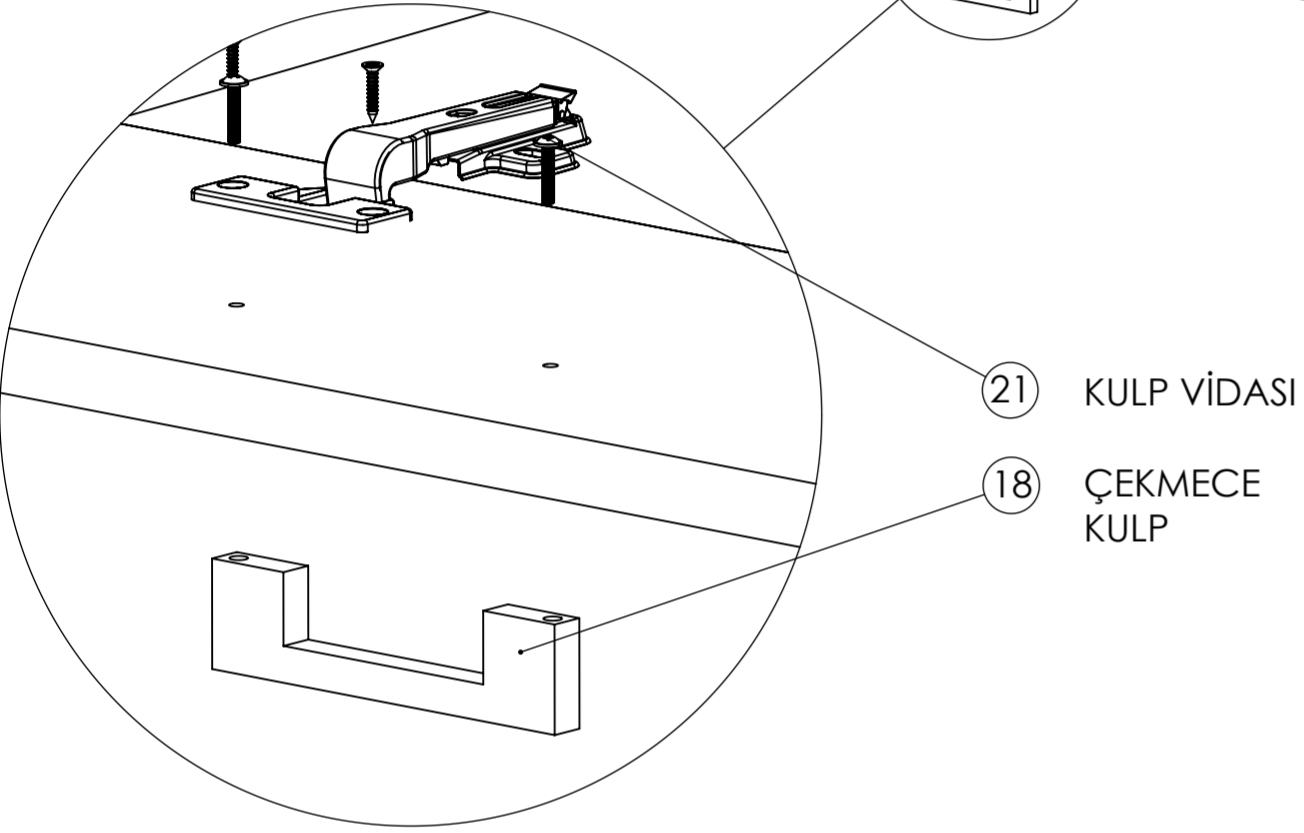
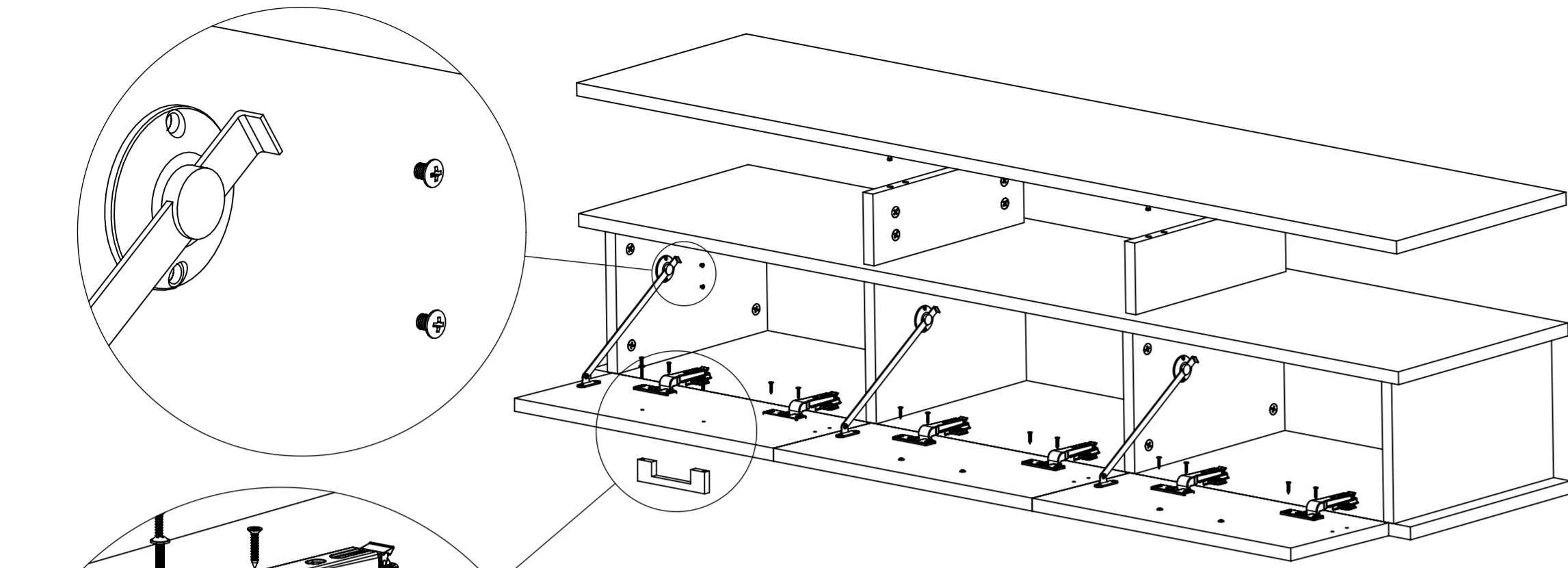

F

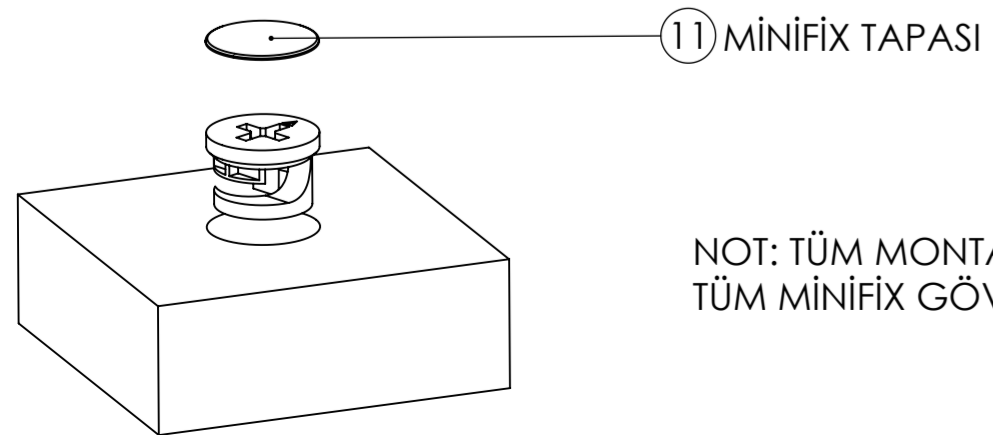
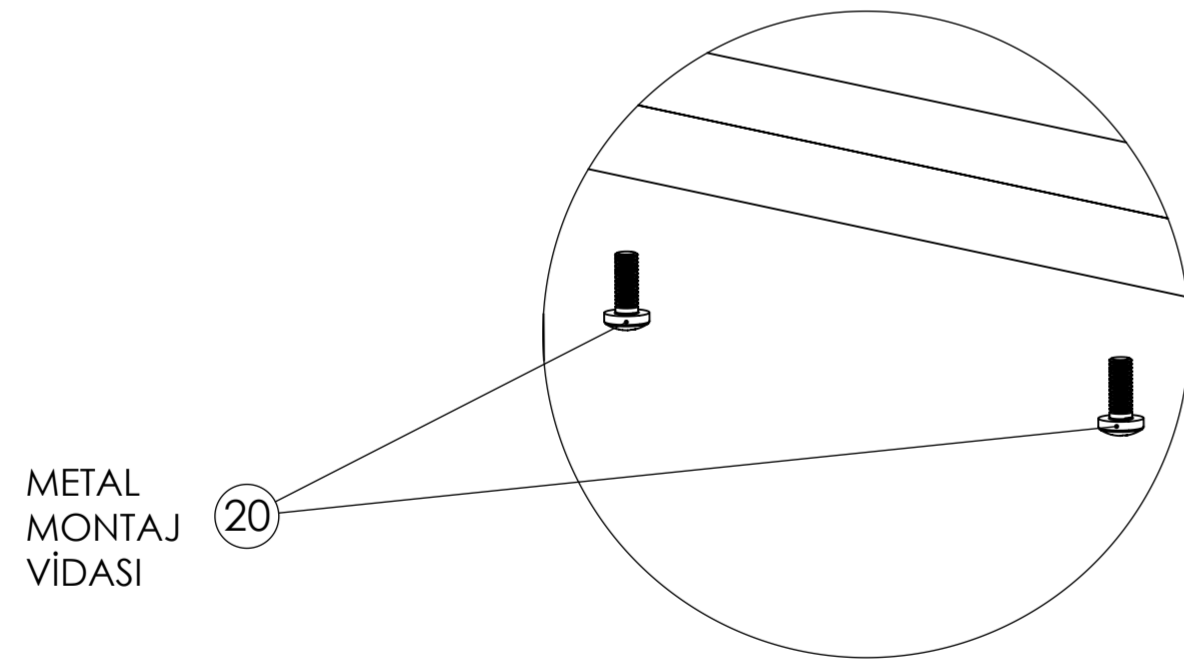

NOT: TÜM MONTAJ BİTTİKTEN SONRA 11 NOLU MİNİFİX TAPASI, TÜM MİNİFİX GÖVDELERİN ÜZERİNE MONTE EDİLİR.

